

Motor Driver(5-Phase microstepping driver)

MD-255C/355C Rev 1.0

M A N U A L

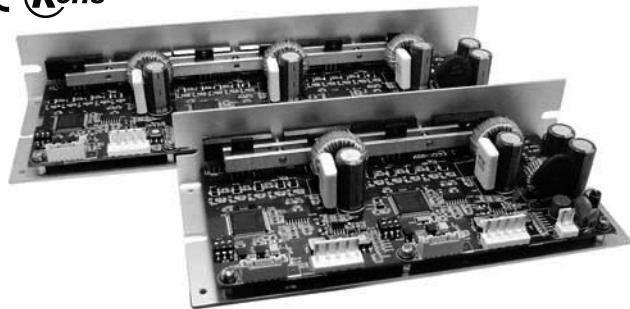

Thank you very much for selecting Kohzu products.
For your safety, please read the following before using.

Caution for your safety

- *Please keep these instructions and review them before using this unit.
- *Please observe the cautions that follow:
- Warning** Serious injury may result if instructions are not followed.
- Caution** Product may be damaged, or injury may result if instructions are not followed.
- *The following is an explanation of the symbols used in the operation manual.
- Caution** : Injury or danger may occur under special conditions.

Warning

- In case of using this unit with machinery(Nuclear power control, medical equipment, vehicle, train, airplane, combustion apparatus, entertainment or safety device etc), it is required to install fail-safe device.**
It may cause a fire, human injury or give an electric shock.
- Installation, connection, operation, control, maintenance should be carried out by person who has been qualified.**
It may cause a fire, electric shock or human injury.
- Please use DC power with reinforced insulating the primary and secondary part for the DC power product.**
It may give an electric shock.
- Please install this unit after consider countplan against power failure.**
It may cause human injury or damage to product by releasing holding torque of motor.
- Do not use this unit outdoors or place where there are explosiveness, flammable, corrosive gas, water and frequent vibration etc.**
It may cause a fire or give an electric shock.
- Do not disassemble and modify this unit, when it is required, please contact us.**
It may cause a fire, give an electric shock or damage to product.
- Please install board type product with protection equipment.**
It may cause a fire.

Caution

- Power input voltage must be used within rated specification and power line should be over than AWG NO. 18(0.75mm²).**
It may cause a fire or give an electric shock.
- Please check the connection before supplying the power.**
It may cause a fire or give an electric shock, damage to product.
- Please turn off the power when power is failed.**
It may cause human injury or damage to product due to sudden movement by recovering from power failure.
- Do not touch during the operation or after a while of operation.**
It may cause a burn due to high temperature in surface.
- The emergency stop should be enabled during the operation.**
It may cause human injury or damage to product.
- Please apply power after checking control input signal.**
It may cause human injury or damage to product by sudden movement.
- Do not turn on the HOLD OFF signal input while it is maintaining vertical position.**
It may cause human injury or damage to product by releasing holding torque of motor.
- Please install a safety device when it is required to remain the vertical position after turning off the power.**
It may cause human injury or damage to product by releasing holding torque of motor.
- Please check if HOLD OFF signal input is ON when it is required to set the output manually.**
It may cause human injury by sudden movement.
- Please stop this unit when mechanical problem is occurred.**
It may cause a fire or human injury.
- Do not touch the terminal when during the insulation dielectric strength test or insulation resistance measurement.**
It may give an electric shock.
- Please observe rated specification.**
It may cause a fire, give an electric shock or damage to product.
- In cleaning the unit, do not use water or an oil-based detergent.**
It may cause a fire or give an electric shock.
- Please separate as industrial waste when disuse this unit.**

*The above specifications are changeable at anytime without notice.

Features

- Simultaneous operation of 2, 3-axis by single 24VDC.
- Wide step angle by switching signal.
- Settable 16 step angles and enable to rotate with 250 microsteps and 125000pulse.
- Includes auto current down, self-diagnosis function.
- Small, light weight and advanced quality by custom IC and surface mounted circuit.
- Photocoupler input insulation method to minimize the effects from external noise.

Input

- Pulse width : Min. 0.25μs
- Pulse interval : Min. 0.25μs
- Rising/falling time : Max. 1μs
- Max.input pulse frequency : 500 kpps
- Pulse input voltage : [H]4V~8V [L]0~0.5V
- Input inner resistance : 270Ω (CW, CCW), 390Ω (HOLD OFF, DIVISION SELECTION)

Specifications

Model	MD-255C	MD-355C
Power supply	20~35VDC 5A[Max.](−10%, +20%)	20~35VDC 7A[Max.](−10%, +20%)
RUN current	0.35 ~ 1.4A/Phase(Max.)	
RUN method	Bipolar constant current pentagon drive	
Resolution	1, 2, 4, 5, 8, 10, 16, 20, 25, 40, 50, 80, 100, 125, 200, 250 of microstep	
Ambient temperature	0 ~ 40°C	
Ambient humidity	35 ~ 85%RH(at non-freezing status)	
Storage temperature	20~60°C(at non-freezing status)	
Unit weight	Approx. 292g	Approx. 411g

*There is torque difference by input power.

Dimensions

○MD-255C

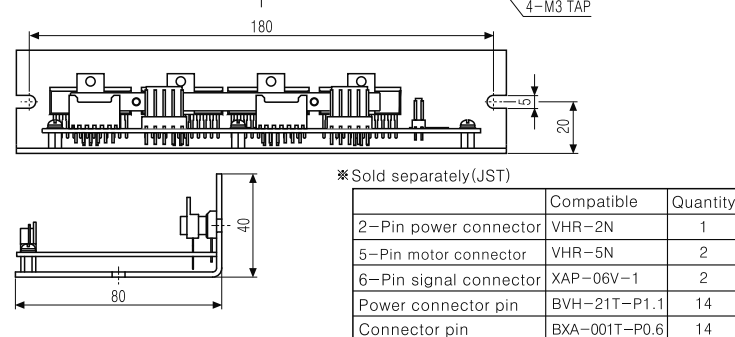
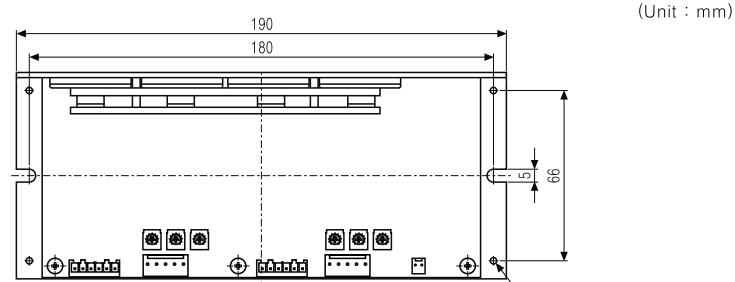

○MD-355C

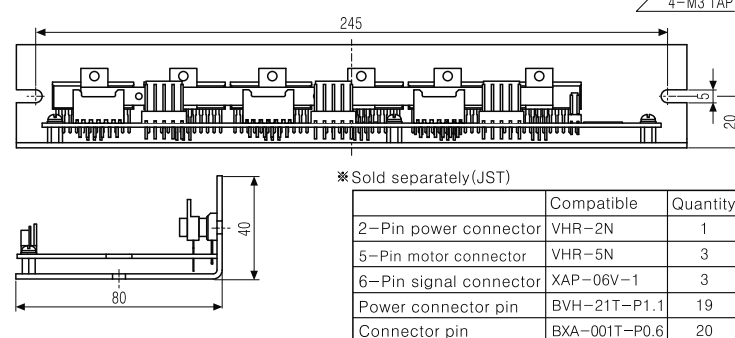
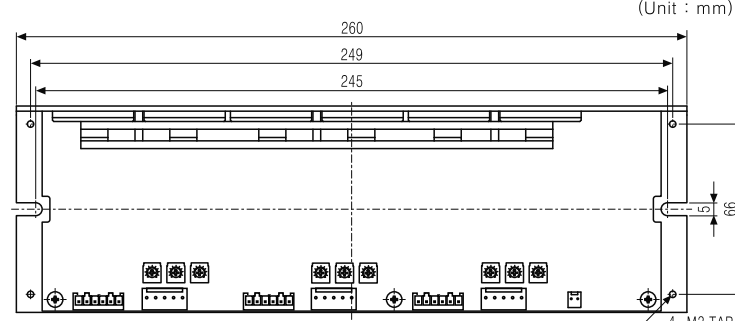

Time charts

○2 Pulse input

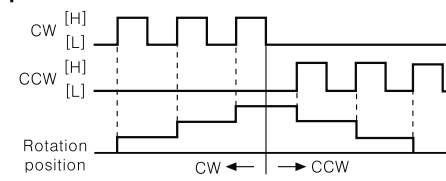

○1 Pulse input

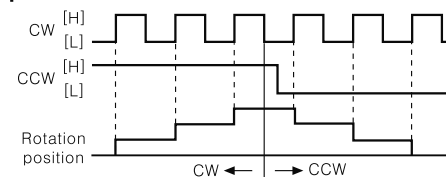

Note) Do not input CW, CCW signals at the same time in 2 Pulse input type.
It may not work properly if another direction signal is supplied when one of them is ON.

Input · Output diagram

<MD-255C/355C Driver inner circuit>

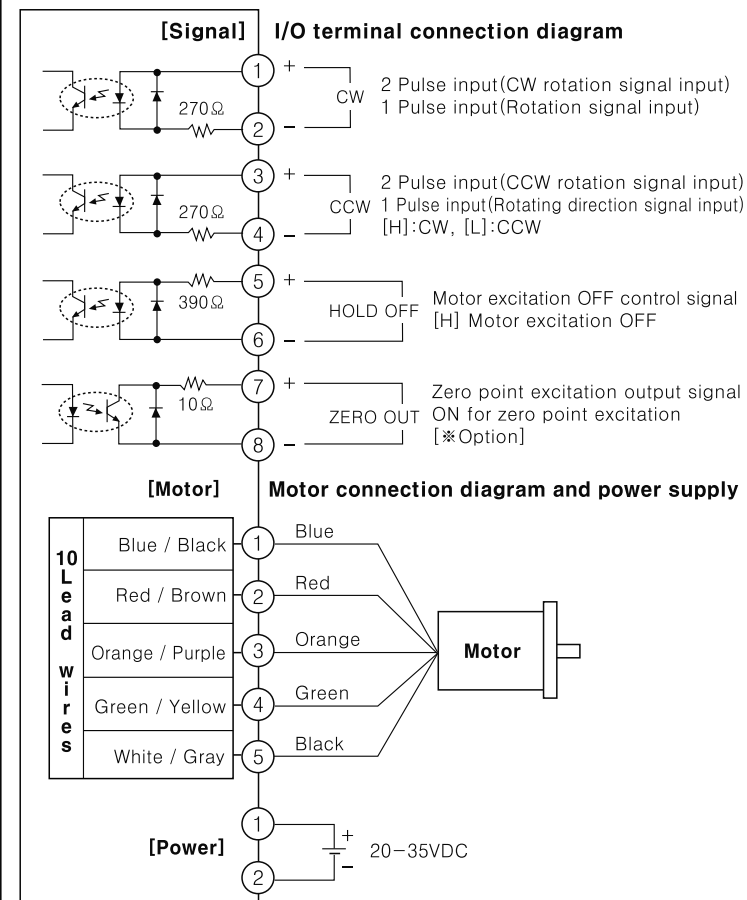

Note)Add external resistance when power for pulse from the external of the unit exceeds +5V.

Function

○Selectable function switch

No	Name	Function	Switch position	
			ON	OFF
1	TEST	Self diagnosis function	250pps rotation	Normal
2	1/2 CLK	Pulse input method	1Pulse input	2Pulse input
3	CURRENT DOWN	Auto Current Down	Not use	Use

- **TEST**
 - It rotates at a speed of 250pps in Full Step and it is changed depending on resolution.
 - It rotates to CCW in 1 Pulse input method and CW in 2 Pulse input method.
- **1/2 CLK**
 - Pulse input method selection
 - 1 Pulse method : Input pulse signal input in CW and rotating direction signal in CCW. It rotates to CCW when [L] and CW for [H].
 - 2 Pulse method : Motor is rotated to CW when input pulse in CW and to CCW when input pulse in CCW.
- **CURRENT DOWN**
 - It reduces RUN current when motor is at standstill to lower the heat generation automatically.
 - Current is reduced from approx.500[ms] after the last pulse input.

○Setting of RUN current

Switch No	0	1	2	3	4	5	6	7	8	9	A	B	C	D	E	F
Current (A/Phase)	0.35	0.42	0.5	0.58	0.66	0.75	0.8	0.85	0.92	0.98	1.05	1.12	1.18	1.26	1.32	1.4

- RUN current is phase current provided to 5-phase stepping motor.
- RUN current is set under the rated current, or, it may cause loss of torque.
- Torque is increased as raise RUN current, but, motor emits heat too much, select depending on the load.

○Setting of STOP current

Switch No	0	1	2	3	4	5	6	7	8	9	A	B	C	D	E	F
%	27	31	36	40	45	50	54	58	62	66	70	74	78	82	86	90

- It sets current when motor is at standstill.
- Set STOP current is percentage of RUN current.
- It is operated when HOLD OFF is [L]. Current supplied to each phase is cut in [H], auto CURRENT DOWN function does not work.

○Zero point excitation output signal(ZERO OUT)[*Option]

- It indicates the initial step of excitation status of stepping motor and rotation position of motor axis from previously set zero.
- ZERO OUT means the initial status of motor excitation(STEP 0), it outputs per 7.2° of rotation in Full Step.(It outputs 50times per 1 rotation of motor.)
Ex) Full step : It outputs one time when input 10 pulse.
20 division : It outputs one time when input 200 pulse.

○HOLD OFF function

- HOLD OFF is [H], the excitation is released.
- HOLD OFF is [L], the excitation is in a normal status.
- It rotates motor axis by external force or is used for manual positioning.
- Input H/L means ON/OFF of photocoupler in a circuit.

○Setting microstep(Microstep : Resolution)

Switch No	0	1	2	3	4	5	6	7	8	9	A	B	C	D	E	F
Resolution	1	2	4	5	8	10	16	20	25	40	50	80	100	125	200	250

○Setting resolution(MS1)

- It operates as MS1 when DIVISION SELECTION signal is [L] and MS2 for [H].
- It enables to adjust resolution during the motor operation and operate as microstep by DIVISION SELECTION signal.
- The calculation formula of divided step angle is as below.
Rotation angle of 5-phase stepping motor = $\frac{\text{Basic step angle}(0.72^\circ)}{\text{Resolution}}$
- When resolution is changed during the operation of motor, it may cause a step-out of motor.

Caution for using

- Caution for signal input
 - Do not input CW, CCW signal at the same time in 2 Pulse input type. It may not work properly if another direction signal is supplied when one of them is ON.
 - Current value of power supply in specifications is max.input of driver.
 - Use power enough to supply RUN current for power input.
- Caution for wiring
 - Use Twist pair(Over 0.2mm²) for the signal wire should be shorter than 2m.
 - Use electric wire of AWG No.18(0.75mm²) for motor (when extend) and power connection.
 - Check the power polarity before the operation.
- Caution for installation
 - Please mount a heating panel on metal surface closely.
 - Please mount this product at well-ventilated place in order to increase the heating efficiency of heating panel.
- Caution for using function switches
 - Self-diagnosis function is enable to test motor and driver when 250pps pulse is outputted in [ON] status.
 - Check self-diagnosis switch is [OFF] before power ON, or, it may start to drive instantly when it is ON.
 - Auto CURRENT DOWN function is used to reduce RUN current when motor is at standstill to lower the heat generation automatically.
- Installation environment
 - It shall be used indoor
 - Altitude Max. 2000m
 - Pollution Degree 2
 - Installation Category II

*It may cause malfunction if above instructions are not followed.



Kohzu Precision Co., Ltd.
2-6-15 Kurigi, Asao-ku, Kawasaki Kanagawa 215-8521, Japan
Telephone: 81-44-981-2131
Facsimile: 81-44-981-2181
Email: e-sale@kohzu.co.jp
Web: http://www.kohzu.com/