



Operation Manual

Stage Controller

Model **SC-021**



Thank you for purchasing this product.

Before use, be sure to read this “Operation Manual” carefully for correct operations.

Keep this Operation Manual in a convenient place so that it can be referred to at any time when in doubt.

Ver.1.00



Version of this manual is not related to that of SC controller.

Pioneering the door to the future with a commitment to technology

KOHZU Precision Co., Ltd.

Precautions in Use

Symbols Identifications

-  This symbol indicates that there are descriptions that call attention (including warnings to the user). Make sure to read the descriptions when reading this manual.
-  This symbol indicates prohibitive activities. Make sure to read the descriptions when reading this manual.
-  This symbol indicates descriptions as reference or remarks.











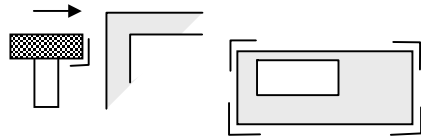

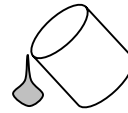

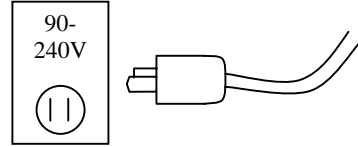
		Do not apply strong impact to the product. And avoid using in a place where vibration occurs frequently.
		Liquid or chemical splashes on this device are dangerous and cause failures. Never use this device in such places.
		Use 100V AC (50/60Hz) as a power supply. Confirm ratings of the power cable. The power cable (3P) for AC100V is attached usually.
		This product is precision electronic equipment. It may malfunction near large sized-generating machinery or high voltage equipment, or equipment generating strong magnetism. Avoid using in such environments.
		Do not remove the fixed panel and cover needlessly except in cases where adjustment or setting of the integrated driver must be adjusted.
		Never rework or replace parts for use.
		Pay close attention when connecting the motor driven stage or a motor other than those specified by us.
		When the controller's power supply is turned ON, do not perform exclusion and adding of cables.

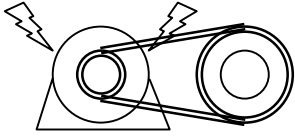
Table of Contents

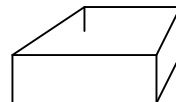
1.Introduction	1
1-1.Features of the Product	1
Outside of Product Range	
1-2.Product Configuration	2
1-3.Positioning Method	3
(Driving Method)	
2.Installation and Preparation	4
2-1.Proceeding with Installation and	4
Preparation	
2-2.Attachment and Options	5
2-3.How to Connect Cables	7
3.Functions	9
3-1.Speed Setting	9
3-2.Trapezoidal Drive and S-shape	11
Drive	
3-3.Origin Return Method	12
3-4.Limit Stop	20
3-5.Feedback	21
3-6. Backlash Correction	25
4.Part Names and Functions	27
4-1.Front Panel	27
4-2.Rear Panel	27
4-3.DIP Switch	28
(RS-232C Setting Switch)	
5.Remote Control	29
5-1.Remote Control	29
5-2.List of Commands	32
5-3.Details of Commands	34
5-4.Error Code	75
6.Internal Motor Driver	78
6-1.Driver Specifications	78
6-2.Arrangement of Driver	79
6-3.Open and Close Enclosure,	80
Adjustment of Driver	
6-4.Change in Encoder Input System	82
7.Maintenance and After-Service	83
7-1.Before you judge as failure	83
7-2.Maintenance of Product	85
7-3.Contact	86
7-4.Warranty and After-Service	87
8.Specification	88
8-1.General Specifications	88
8-2.Performance Specifications	88
8-3.Connector	89
8-4.Exterior Dimensions	90
9.Attached CD-R	91
9-1.Configuration	91
9-2.Sample Software	91
Appendix	92
System Setting List	92
List of Commands	94
Revision History	

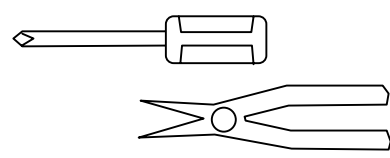
1. Introduction

1-1. Features of the Product

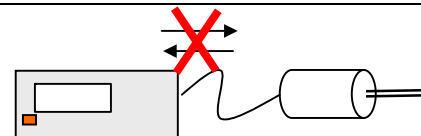
Thank you for purchasing our stage controller SC-021.

SC-021 comprise extremely high cost performance products realizing a low price while featuring remarkable functions in comparison with conventional motor controllers.

Completely corresponds to our motor drive precision stage <MontBlanc Series>. Micro step driver allowing for 250 splits at maximum is equipped as standard. Corresponds to the trapezoid drive. Asymmetric trapezoid drives are also possible. Realizes smooth drive by S-shape drive. Asymmetric S-shape drives are also possible.

Origin return method can be selected from 14 kinds.

Backlash correction function is equipped as standard.
Feedback control by encoder input is equipped as standard.

In conformity with EIA standards. Allows for integration with cabinet rack.
Analog type joystick with excellent operability is equipped as standard.

Remote control by RS-232C communication is possible.

Corresponds to the RoHS instruction.

Outside of product range: This product does not offer the following items.

- SC series controller cannot drive motors other than a 5-phase stepping motor.
- Not compatible with motors with an electromagnetic brake.
- No program function equipped. Automatic operation should be performed on the personal computer side.
- Not compatible with remote controls (sequencer connection, etc.,) other than RS-232C communications.

1-2. Product Configuration

Product configuration of SC-021 Series is as follows.



SC-021

2-axis driver integrated

1-3. Positioning Method (Driving Method)

SC Series allows for positioning control by the following methods.

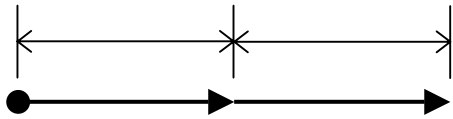
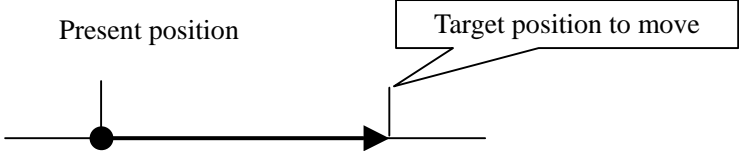
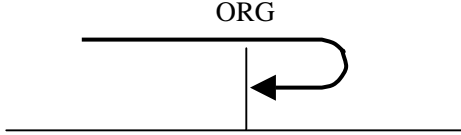
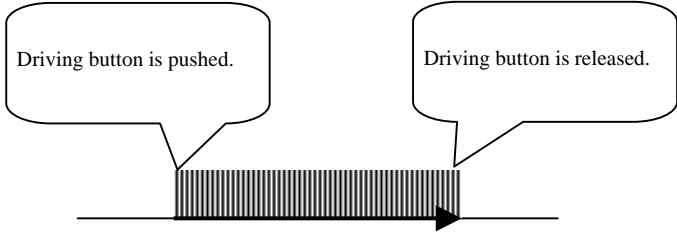
<p>Relative Position Movement</p>	<p>Moves toward the designated direction from the present position by a set value.</p> <p>Present position</p> <p>Movement amount Movement amount</p> 
<p>Absolute Position Movement</p>	<p>Moves to the designated position.</p> <p>Present position</p> <p>Target position to move</p> 
<p>Origin Return Movement</p>	<p>Returns to the origin point according to the specified origin return method.</p> <p>ORG</p> 
<p>Joy Movement (Only for Sample Software)</p>	<p>Moves continuously by joy stick mode for Sample Software.</p> <p>Driving button is pushed.</p> <p>Driving button is released.</p> 

2. Installation and Preparation

2-1. Proceeding with Installation and Preparation

Install the product in the following order.

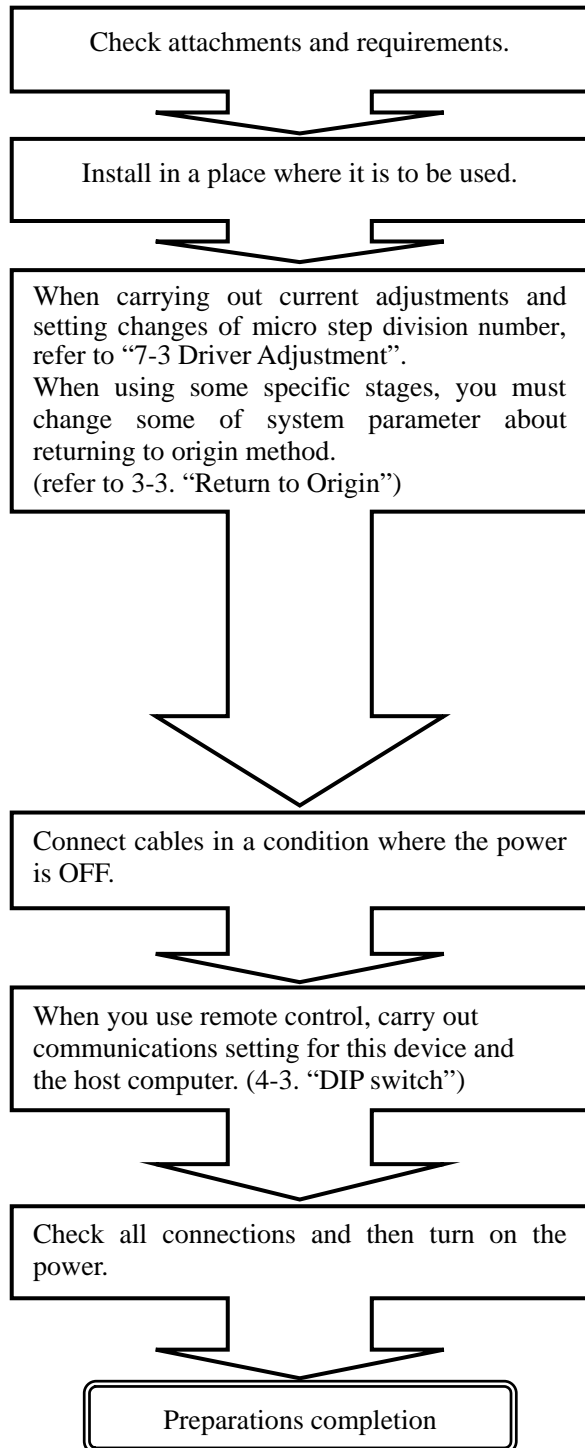

 Contact your retailer or our sales department immediately if any attachment is lost.

 Do not install in a high temperature, low temperature or high humid location, or where noise frequently occurs.

 “Driver Adjustment”
Our products are normally adjusted in accordance with customer use objectives prior to shipment. This adjustment is required if you attempt to change settings, or if this controller is shipped without stages.

 “Return to Origin”
Some models of our standard stages can’t perform returning to origin normally unless you change setting for method of returning to origin.

This adjustment is required if this controller is shipped without stages.

 Make sure to check that the power switch is OFF.

Connect Power cables, stage connections and communications cables.

 If you notice abnormalities such as an abnormal noise or smell, immediately turn off the power and investigate the cause.

2-2. Attachments and Options

2-2-1. Attachments

The following items are attached to the products. Make sure to check that all items are included. Immediately contact us if any lost, or any attachments broken.

Power cable (3P)

power cable (3P) for AC100V is attached usually.

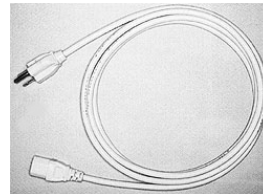

CD-R (including Operating Manual)



Motor cables and communications cables such as RS-232C(Cross type) are not included. Separately purchase the stage connecting cable.

Additionally, for the communications cable, commercially available cables can be used, therefore, please purchase it yourself.



In order to save paper resources, a printed Operating Manual is not included. Print the file inside the CD-R if necessary.



The file of the Operating Manual is an Acrobat (PDF) format.

In order to view the PDF format file, Adobe Reader of Adobe Systems Inc. is required. Adobe Reader is not included in this CD-R.

2-2-2. Optional Products

The following optional products are prepared to use SC-021.

Motor Cables : This cable connects SC-021 with a precise stage.

Connector shape (stage side)	Length	Standard Cable
Rectangular connector	3m	CA1303
	5m	CA1305
	10m	CA1310
Round type connector	3m	CB1303
	5m	CB1305
	10m	CB1310

2-3. How to Connect Cables

It explains connection/connecting wires of SC-021 and an external equipment.

 When pulling out or plugging in all cables such as the power cable, motor cables and communications cable, carry out connections in a state where the power is turned OFF.

【Front Panel】

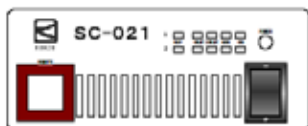

【Rear Panel】

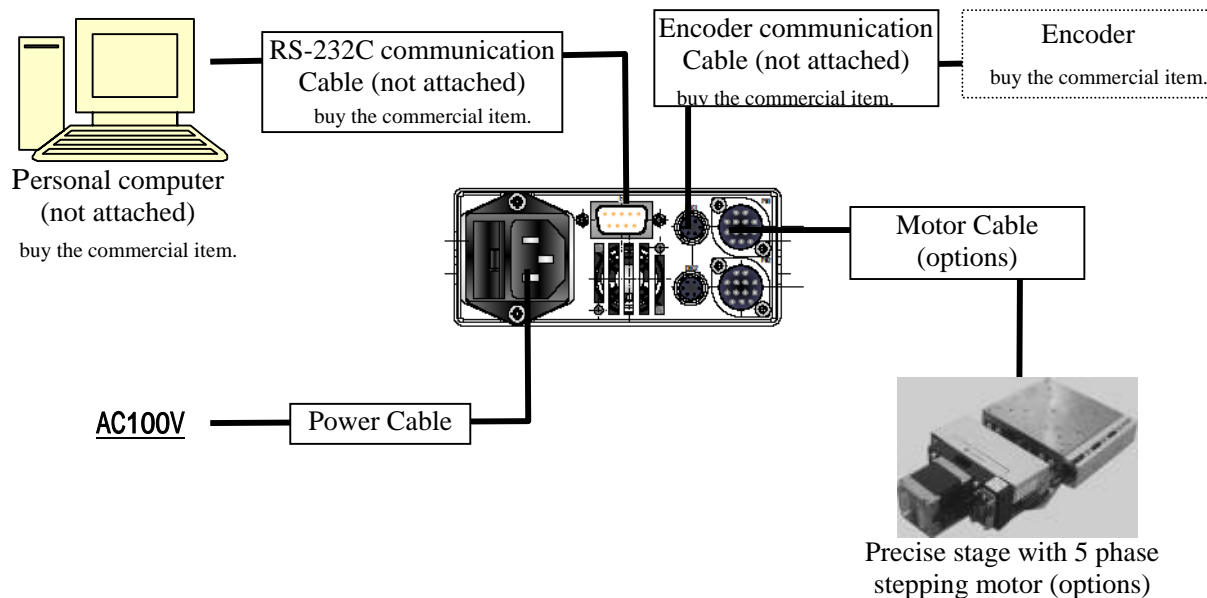

MEMO

3. Functions

3-1. Speed Setting

3-1-1. Speed Table

With SC Series controller, you can set speed by a 1pps unit in a range from 1 to 4,095,500pps. However, there are typically many cases where fine speed setting is not required, so we adopt a method for selecting a setting from the **ten stages of the Speed Table** in order to easily perform speed setting.

(Setting for 1pps unit can be performed. Refer to **Table No.0** below.)
 Speed can be designated for each axis.

Speed Table values of the below table are initial values.

Speed Table No.	Start speed	Top speed	Accelerating time(×10ms)	Decelerating time(×10ms)
0	500	5000	24	24
1	500	2000	20	20
2	500	3000	24	24
3	500	4000	28	28
4	500	5000	32	32
5	500	6000	36	36
6	500	7000	40	40
7	500	8000	44	44
8	500	9000	48	48
9	500	10000	52	52
10	10	8000	50	15
11	1	200	1	1

Speed Selection

Joystick High Speed (PHi)

Joystick Low Speed (PLo)

Speed Table No.0

Select Speed table No.0 to do a detailed setting at the speed and the acceleration and deceleration time.

You can change and refer to the set values of speed table No.0 by the ASI/MSI/RMS command in remote control.

You can change and refer to them also by operating the system construction (SYS mode) in manual operation.

Speed Table No.1-9

You can change and refer to the setting values of speed table No.1-9 by the **WTB/RTB** command in remote control.

You can change and refer to them also by operating the system construction (SYS mode) in manual operation.

In manual control, you can change the speed table No.1-9 when the coefficient is set with SYS No.35.

Speed Table No.10,11

With speed table No.10 and No.11, speed setting in jog movement by the joystick can be performed. No.10 is for a setting at a high speed (screen display: PHi) and No.11 is for a setting at a low speed (screen display: PLo).

You can change and refer to a set value of speed table No.10-11 by the **WTB/RTB** command when remotely control.

You can change and refer to it also by operating the system construction (SYS mode) when the manual control.

In manual operation, the speed is automatically changed when the coefficient is set with SYS No.35.

3-1-2.. Speed Change in Remote Control

In remote control, designate speed table No. in each driving command.

Command Example

`stx` `RPS1/2/0/3/1000/0/0/0` `GRLF`

(Example of relative movement command)

Set the speed table No.3.

3-2. Trapezoidal Drive and S-Shaped Drive

When moving an object, it cannot be suddenly moved at a high speed because of inertial force. In general, a stepping motor can also start from a low speed, gradually accelerate and reach a high speed.

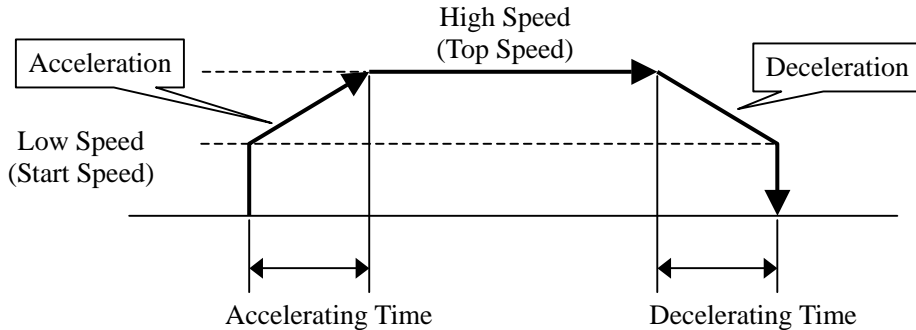

SC Series internally calculate the ratio of acceleration and deceleration and automatically perform a sequence of accelerating and decelerating movements by setting **low speed (start speed)**, **high speed (accelerating time or accelerating STEP)** and **(decelerating time or decelerating STEP)** (in asymmetric drive).

Trapezoidal Drive and Asymmetric Trapezoidal Drive

A method to increase and decrease acceleration and deceleration at a constant acceleration and deceleration ratio is called a trapezoidal drive.

With SC Series, asymmetric trapezoidal drive to accelerate and decelerate at different settings is available.

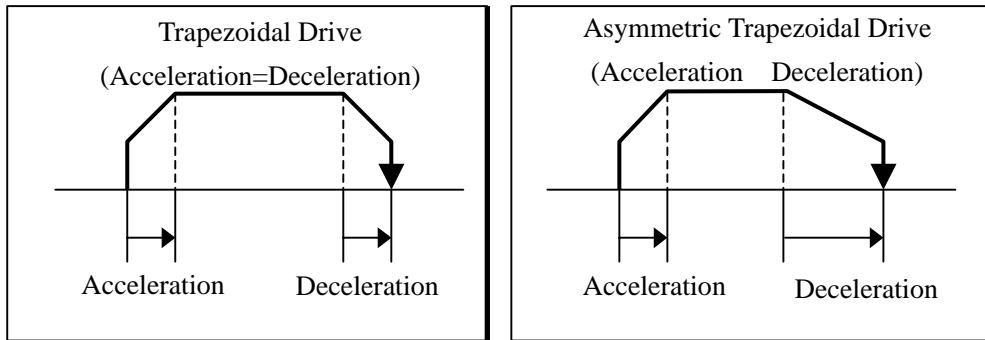

S-Shaped Drive And Asymmetric S-Shaped Drive

S-shaped drive is a method to realize smooth movement by accelerating and decelerating with a quadric curve.

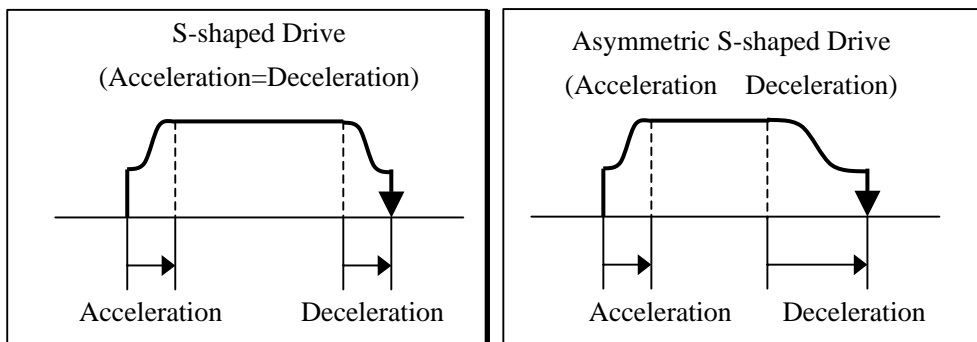

3-3.Origin Return Method

Origin return method can be selected in SC-021 according to the combination of sensors of the positioning device used.

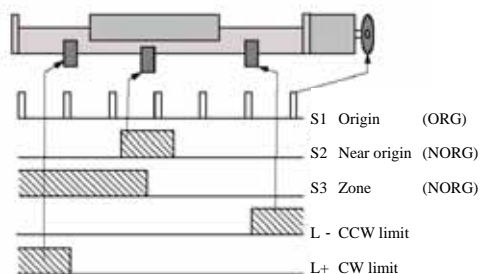

Sensor Configuration

Method	Sensor Configuration	Description
1	S1,S3	Returning direction is determined with zone sensor NORG(S3) and detects origin ORG(S1).
2	S3	Returning direction is determined with zone sensor NORG(S3) and set the edge of the zone sensor NORG(S3) the origin position.
3	S1,S2,L-	ORG(S1) located in NORG (S2) is origin position.
4	S2,L-	NORG (S2) sensor located in moving zone is set to be the origin position.
5	S1,L+	Origin sensor ORG(S1) in proximity of CW limit(L+) is set to be the origin position.
6	S1,L-	Origin sensor in proximity of CCW limit(L-) is set to be the origin position.
7	L+	Edge of CW limit(L+) is set to be the origin position.
8	L-	Edge of CCW limit(L-) is set to be the origin position.
9	S1	ORG (S1) sensor located in moving zone is set to be the origin position.
10	Non	Present position is set to be the origin position. (stage doesn't move.)
11	S1,L+	After the origin position is detected by method 5, and moved by the set amount, this position is set to be the origin.
12	S1,L-	After the origin position is detected by method 6, and moved by the set amount, this position is set to be the origin.
13	L+	After the origin position is detected by method 7, and moved by the set amount, this position is set to be the origin.
14	L-	After the origin position is detected by method 7, and moved by the set amount, this position is set to be the origin.

Default value is method 3.



Most of our standard stages with S1 and S2 sensors adapt in default setting(method 3) but some stages without S1 sensor require to set method 4.



Amounts of the movement from the machine origin in the methods 11 to 14 are set with SYS No. 5.



Stage moves to the neighborhood of the designated sensor at top speed of the speed table, thereafter moves to the origin at start speed(initial setting : 500pps) of the speed table and stops.

3-3-1. Details of Method

Details for each method are described below.

The accelerating and decelerating mode when starting to return to origin depends on system construction.

It explains by using a trapezoid drive method in the following for easiness.

1 Returning direction is determined with zone sensor NORG and detects origin ORG.

When in CCW zone
 Detection starts in CW direction with trapezoidal drive.
 Decelerates and stops when zone sensor is detected.
 Reverses in CCW direction, moves at low speed.
 Reverses in CW direction when moving through zone sensor.
 After being zone sensor detected, stops at first origin.

When in CW zone
 Detection starts in CCW direction with trapezoidal drive.
 Stops by deceleration when moving through zone sensor.
 Reverses in CW direction, moves at low speed.
 After being zone sensor detected, stops at first origin.

S1 Origin (ORG)

S3 Zone sensor(NORG)

Dog (Detecting plate)

Zone sensor(NORG)

Origin sensor (ORG)

CW ← → CCW

— : Hi Speed(Top Speed)
 : Low Speed(Start Speed)

2 Returning direction is determined with zone sensor NORG and set the edge of the zone sensor NORG the origin position.

When in CCW zone
 Detection starts in CW direction with trapezoidal drive.
 Decelerates and stops when zone sensor is detected.
 Reverses in CCW direction.
 Reverses in CW direction when moving through zone sensor,
 moves at low speed.
 Stops at edge of zone sensor.

When in CW zone
 Detection starts in CCW direction with trapezoidal drive.
 Decelerates and stops when moving through zone sensor.
 Reverses in CW direction, moves at low speed.
 Stops at edge of zone sensor.

S3 Zone sensor(NORG)

Dog (Detecting plate)

Zone sensor(NORG)

CW ← → CCW

— : Hi Speed(Top Speed)
 : Low Speed(Start Speed)

3

Origin (ORG) located in origin proximity (NORG) is origin position. (Our standard method)

When in CW zone

Detection starts in CCW direction with trapezoidal drive.
 Decelerates and stops when moving through origin proximity(S2).
 Reverses in CW direction, moves at low speed.
 After being origin proximity detected, stops at first origin.

When in CCW zone

Detection starts in CCW direction with trapezoidal drive.
 Stops when CCW limit is detected.
 (Decelerates and stops if limit deceleration stop is selected.)
 Reverses in CW direction with trapezoidal drive.
 Decelerates and stops when origin proximity(S2) is detected.
 Reverses in CCW direction.
 Reverses in CW direction when moving through origin proximity(S2), moves at low speed.
 After being origin proximity detected, stops at first origin.

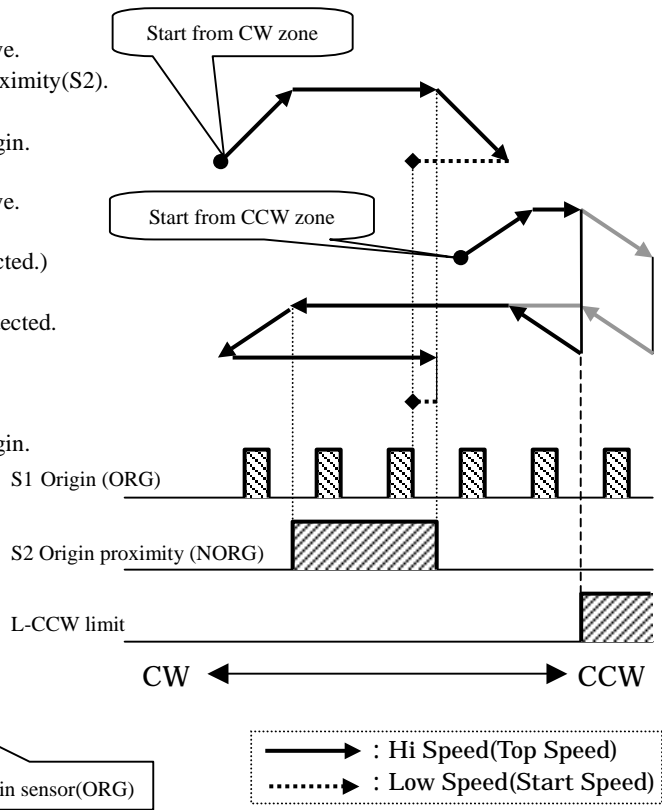
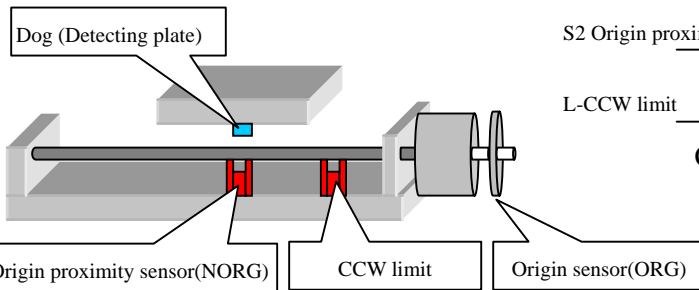

4

NORG sensor located in moving zone is set to be the origin position.



The stage without origin sensor in motor shaft requires this setting.

When in CW zone

Detection starts in CCW direction with trapezoidal drive.
 Decelerates and stops when moving through origin.
 Reverses in CW direction, moves at low speed.
 Stops when origin is detected.

When in CCW zone

Detection starts in CCW direction with trapezoidal drive.
 Stops when CCW limit is detected.
 (Decelerates and stops if limit deceleration stop is selected.)
 Reverses in CW direction with trapezoidal drive.
 Decelerates and stops when origin is detected.
 Reverses in CCW direction.
 Reverses in CW direction when moving through origin,
 moves at low speed.
 Stops when origin is detected.

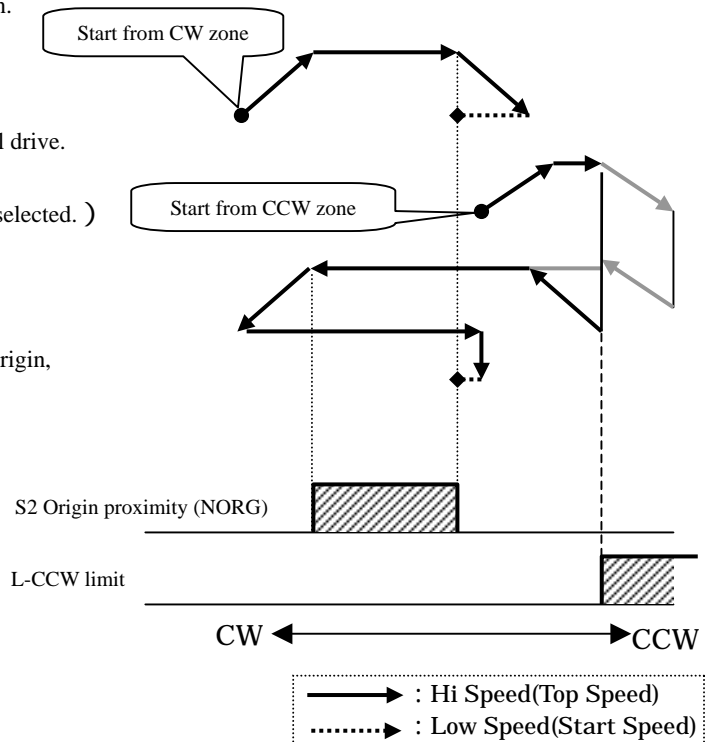
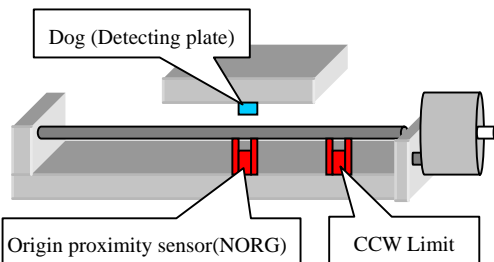

5

Origin sensor ORG in proximity of CW limit is set to be the origin position.

When starting from outside of limit

Detection starts in CW direction with trapezoidal drive.
 Stops when CW limit is detected.
 (Decelerates and stops if limit deceleration stop is selected.)
 Reverses in CCW direction, moves at low speed.
 After moving through CW limit, stops at first origin.

When starting from inside of limit

Moves at low speed in CCW direction.
 After moving through CW limit, stops at first origin.

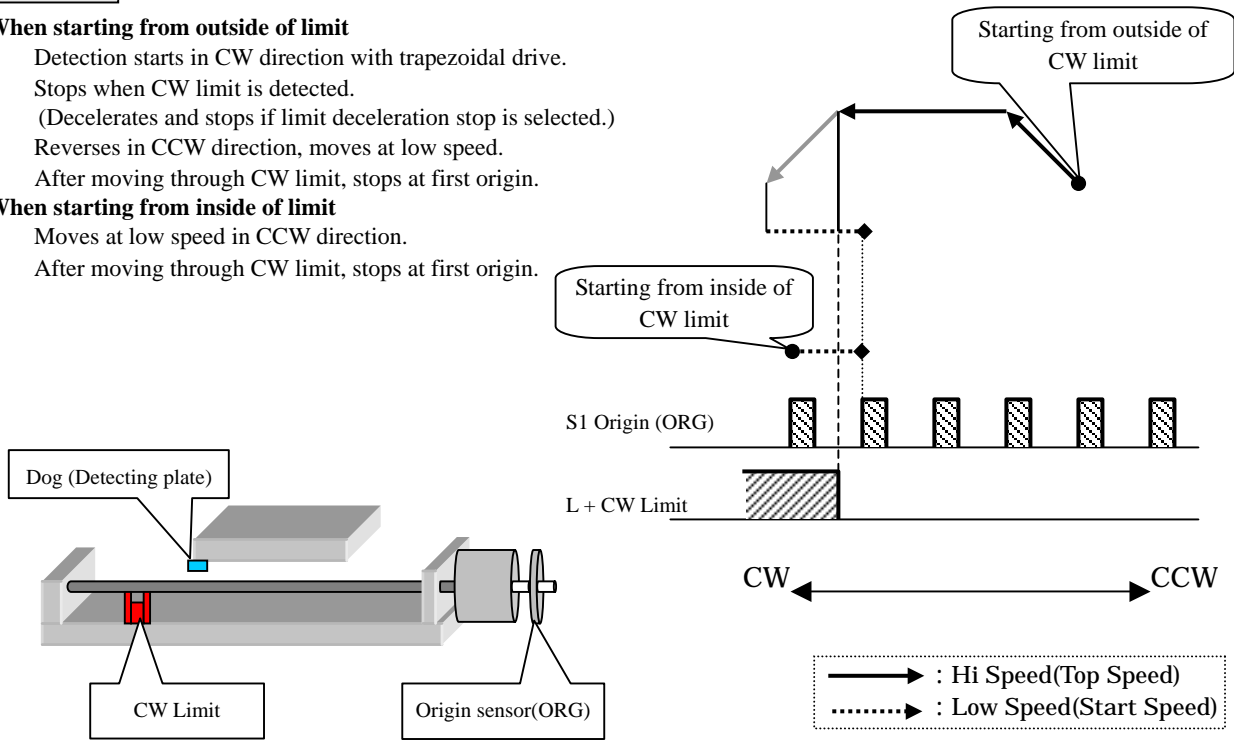

6

Origin sensor in proximity of CCW limit is set to be the origin position.

When starting from outside of limit

Detection starts in CCW direction with trapezoidal drive.
 Stops when CCW limit is detected.
 (Decelerates and stops if limit deceleration stop is selected.)
 Reverses in CW direction, moves at low speed.
 After moving through CCW limit, stops at first origin.

When starting from inside of limit

Moves at a low speed in CW direction.
 After moving through CCW limit, stops at first origin.

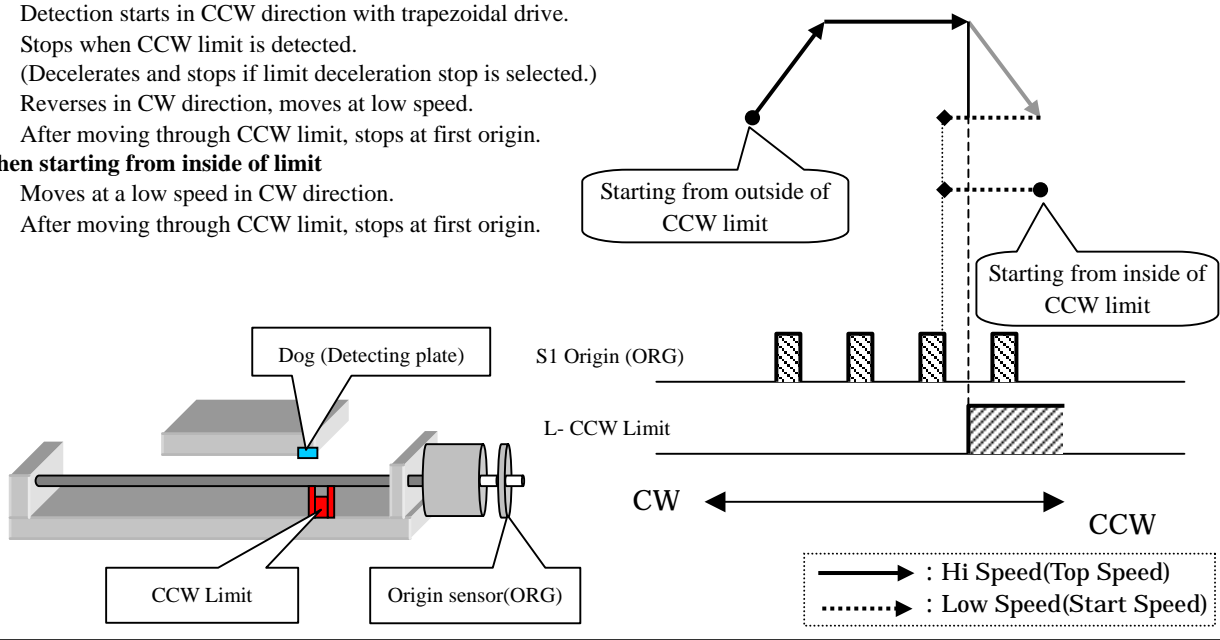

7

Edge of CW limit is set to be the origin position.

When starting from outside of limit

Detection starts in CW direction with trapezoidal drive.
 Stops when CW limit is detected.
 (Decelerates and stops if limit deceleration stop is selected.)
 Reverses in CCW direction, moves at low speed.
 A position where moving through CW limit is origin.

When starting from inside of limit

Moves at low speed in CCW direction.
 Stops at a position when moving through CW limit.

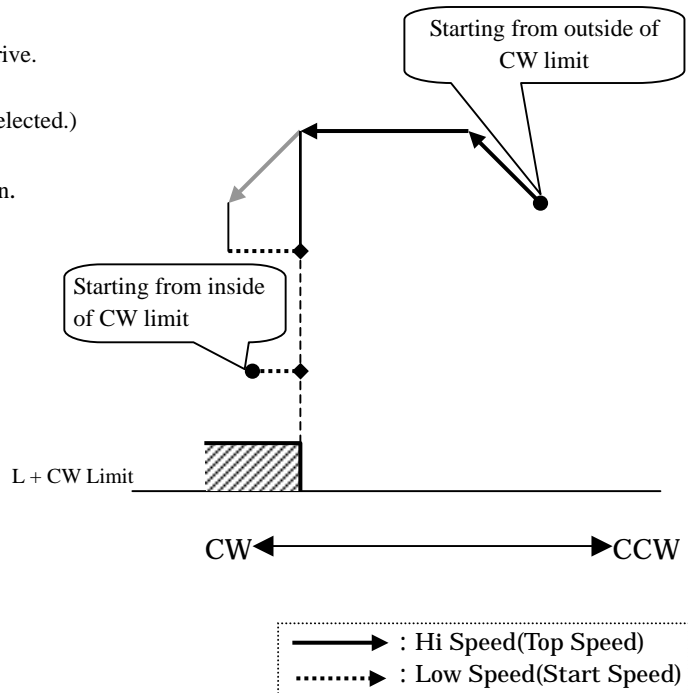
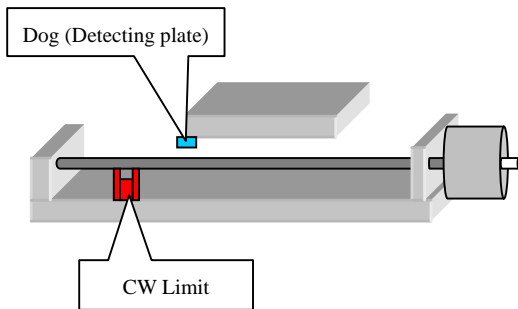

8

Edge of CCW limit is origin position.

When starting from outside of limit

Detection starts in CCW direction with trapezoidal drive.
 Stops when CCW limit is detected.
 (Decelerates and stops if limit deceleration stop is selected.)
 Reverses in CW direction, moves at low speed.
 A position where moving through CCW limit is origin.

When starting from inside of limit

Moves at low speed in CW direction.
 Stops at a position where moving through limit.

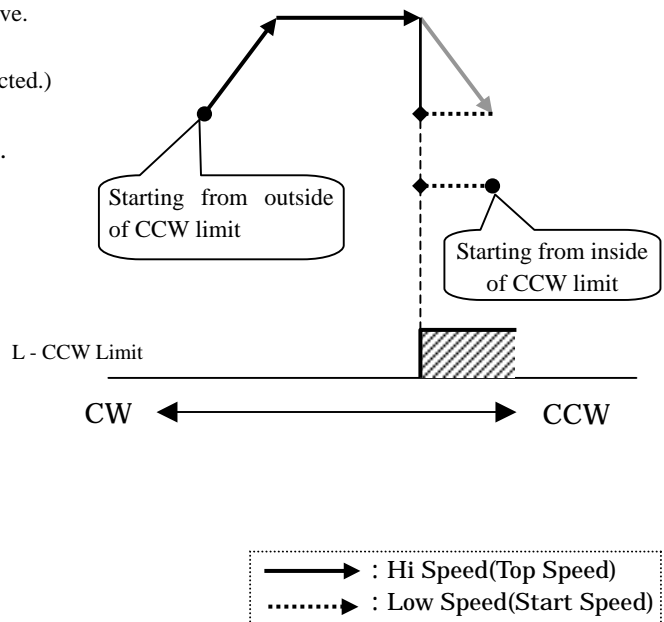
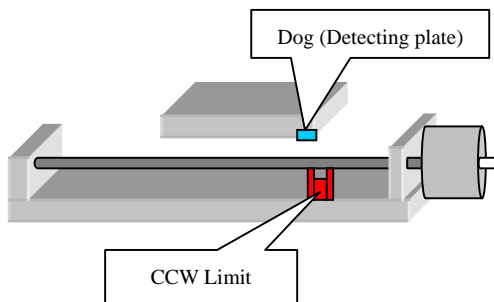

9

ORG sensor located in moving zone is set to be the origin position.

When starting from outside of ORG sensor

Detection starts in CW direction with trapezoidal drive.
 Decelerates and stops when moving through origin.
 Reverses in CCW direction.
 Reverses in CW direction when moving through origin,
 moves at low speed.
 Stops when origin sensor detects.

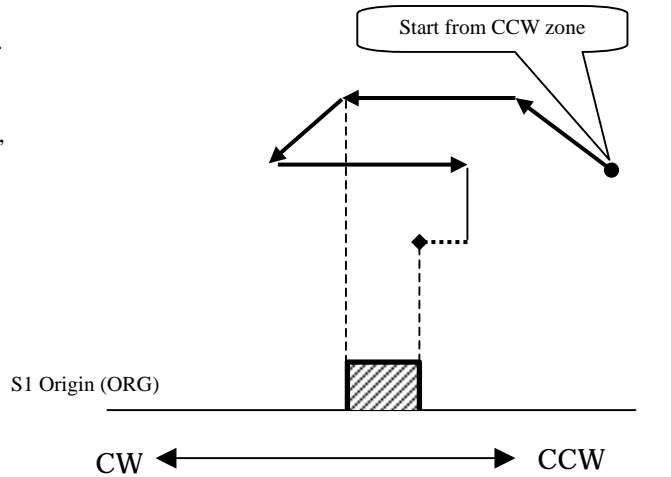
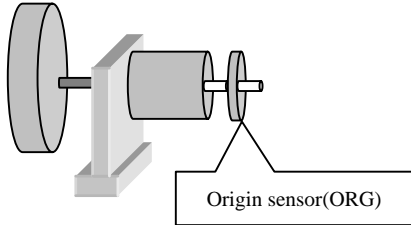

Stops if limit sensor is detected during returning to origin.

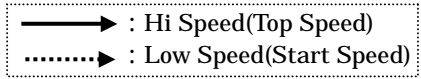

10

Present position is origin position.(stage doesn't move.)

In this mode, the present position is set to be the origin position without driving and it is considered that detection of returning to origin is completed.



Present coordinate value can also be set by setting system parameter No.5 (ORG PRESET DATA).

11

After returning to the origin by method 5, the position is considered as the position set (SYS No.5) and moves to the position of pulse value "0", this position is set to the origin.

In the case of an arrangement as shown in the diagram below, set the parameter No.5 to 1000.

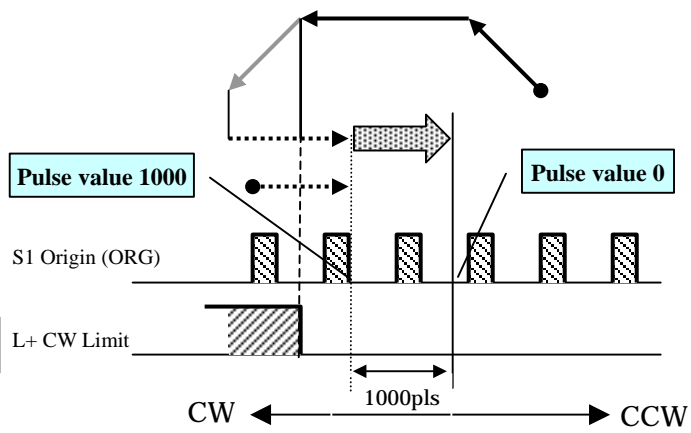
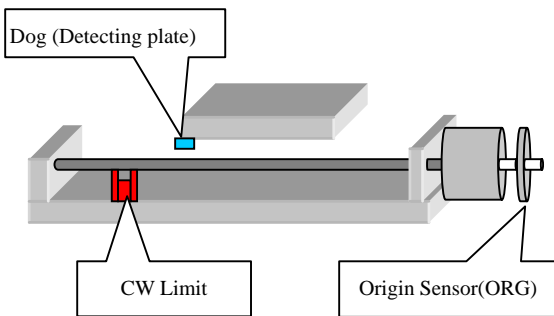

12

After returning to origin in method 6, the position is considered as the position set (SYS No.5) and moves to the position of pulse value "0", this position is set to the origin.
In the case of arrangement as shown in the diagram below, set the parameter No.5 to -1000.

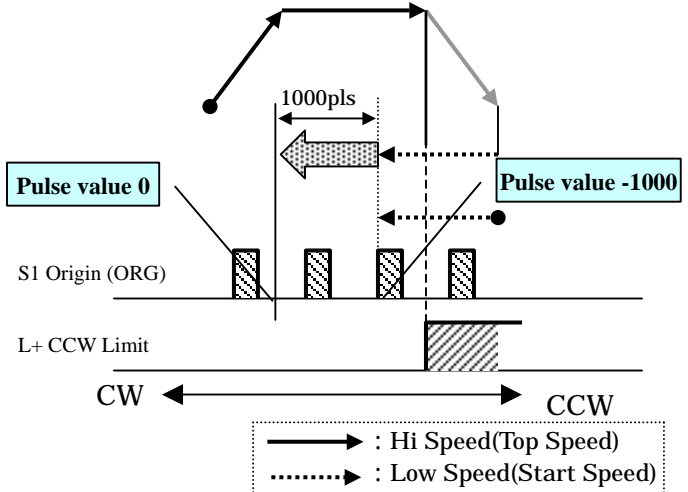
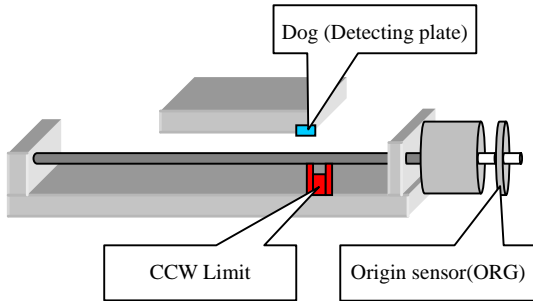

13

After returning to origin in method 7, the position is considered as the position set (SYS No.5) and moves to the position of pulse value "0", this position is set to the origin.
In the case of arrangement as shown in the diagram below, set the parameter No.5 to 1000.

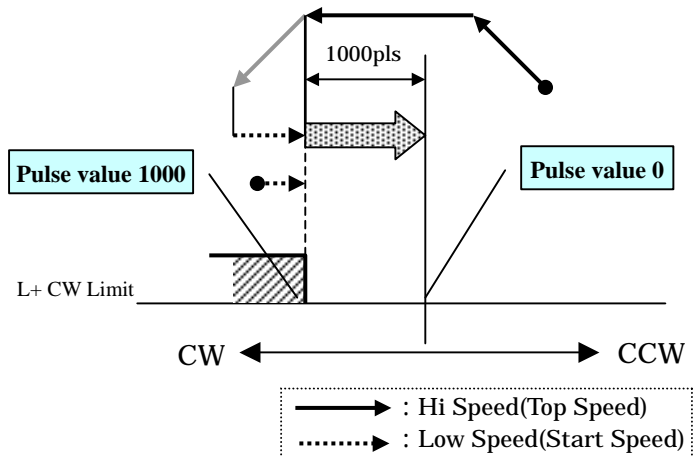
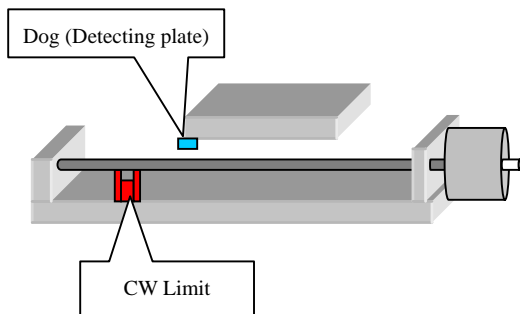

14

After returning to origin in method 8, the position is considered as the position set (SYS No.5) and moves to the position of pulse value "0", this position is set to the origin.
In the case of arrangement as shown in the diagram below, set the parameter No.5 to -1000.

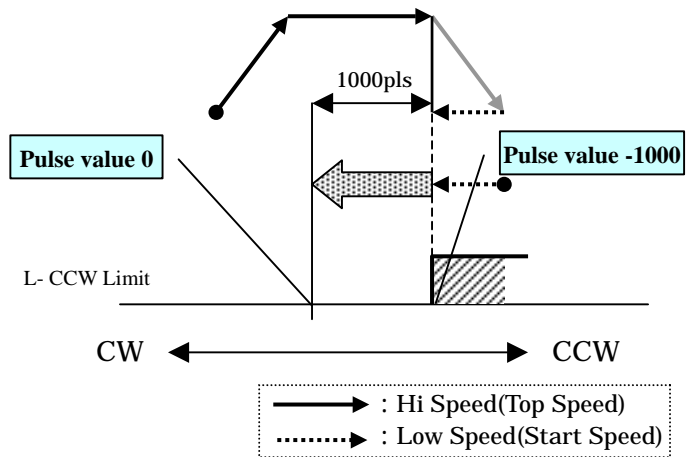
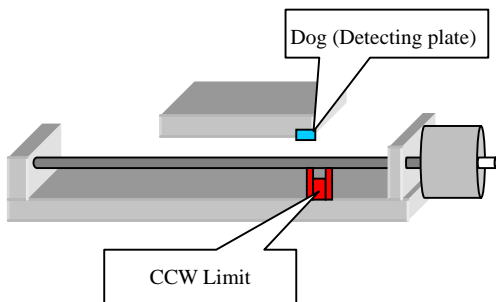

ORG method No.15 is a optional function.

M E M O

3-4. Limit Stop

The controller stops output when a limit signal is detected.
 Stop methods are the following two types.

Setting	Stop Method	
0	Emergency stop	Immediately stops at the limit detected position.
1	Decelerating stop	Decelerates and stops. The decelerating time is the same as that of decelerating setting in normal drive.

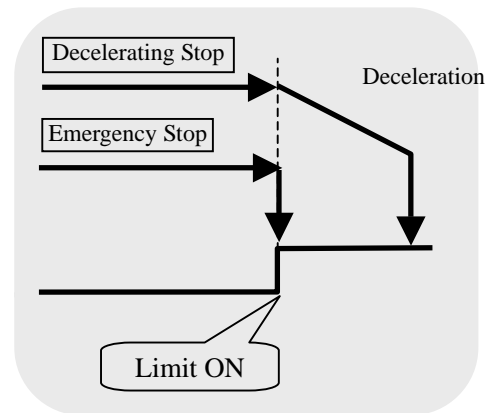

⚠ In standard specifications, in order to eliminate the following trouble, “0: Emergency stop” is fixedly set.
 If you want to use in “1: Decelerating stop,” please contact us.

⚠ To customers who set the “decelerating stop” setting to valid
 In decelerating stop setting, attention must be paid because the amount of overrun becomes large and mechanical failures such as bumping the moving end may occur, if the decelerating time is set to be long.

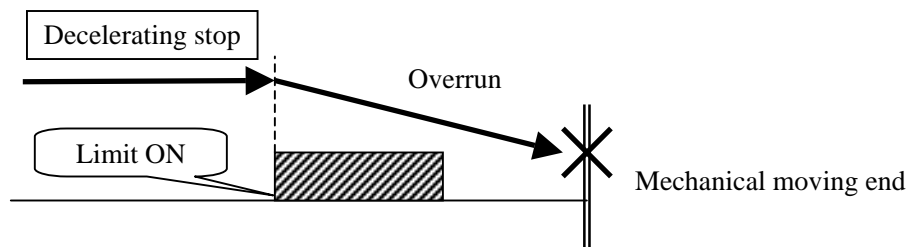

3-5. Feedback

3-5-1. Feedback

As a feature of SC-021, feedback can be performed with encoder input.

Methods for feedback are roughly classified into an incremental method and absolute method. This product adopts the following absolute method.

absolute method

Coordinate value (absolute value) is controlled and feedback control is performed. This product is controlled in below absolute method.

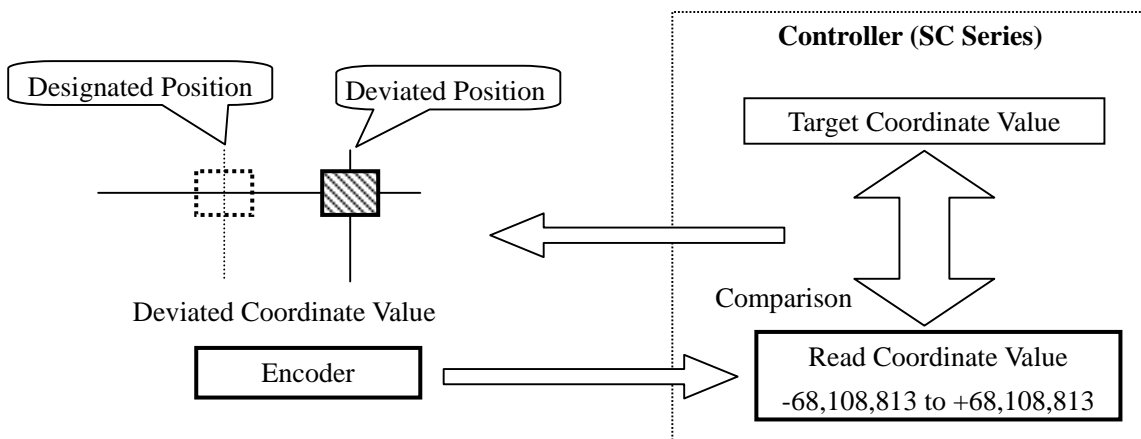

The controller constantly reads coordinate values with signals from the encoder and compares these values with the designated position. When deviation between the read coordinate value and the designated position occurs, the controller drives the motor to reset it to the designated position. The coordinate range that this device can control is a wide range from -68,108,813 to +68,108,813, and the controller can correct pulse in this range even if the position deviates.

3-5-2. Setting of Feedback

In order to perform correction (feedback) by encoder input, settings of items in the following table are required.

When performing setting in manual operation, use “SYS” mode (“5-8. System Setting”), and when in remote operation, perform with the ESI command.

Function	Manual operation (System setting)			Remote operation
	SYS No.	Display	Setting	
Encoder conversion Denominator	24	ENC CAL DIV 1/N	1 to 16,777,215	ESI command
Encoder conversion Numerator	25	ENC CAL DIV N/1	1 to 16,777,215	ESI command
Multiplication setting	26	ENC MULTIPLI 1-4	1,2,4	ESI command
0 clear position	27	ENC PRESCALE	0 to 16,777,215	ESI command
Conversion rounding designation	28	ENC RND OFF 0-9	0 to 9	ESI command
Correction setting	29	FEEDBACK TYPE 0-2	0,1,2	APS/RPS/SPS/ SCN command
Correction Retry number	31	RETRY COUNT	1 to 10,000	ESI command
Correction Wait time	32	WAIT TIME(1ms)	1 to 10,000	ESI command
Encoder adding direction	33	ENC ROTATE CHANGE	0,1	ESI command
Encoder coordinate synchronization	34	PM&ENC SYNC WRITE	0,1	-
Display selection (Second line)	43	SOUR PMC:0 ENC:1	0,1	-
Display selection (Third line)	46	SOUR PMC:0 ENC:1	0,1	-



Make sure to set and adjust the functions marked with  in the above table.

3-5-3. Details of Functions (In Manual Operation)

About remote control, refer to the items for the ESI command.

No.24 **No.25** Encoder Conversion Denominator And Numerator

When minimum resolution for the motor (movement amount per 1 pulse) is different from the minimum resolution for the encoder, set the conversion coefficient with this parameter.

SYS No.	Setting Range	Description
24	1 to 16,777,215	Denominator for conversion
25	1 to 16,777,215	Numerator for conversion

No.26 Encoder Multiplication Setting

Multiply count signal from the encoder to enhance resolution.

SYS No.	Setting Range	Description
26	1	Normal × 1
	2	2 Multiplication × 2
	4	4 Multiplication × 4



Multiplication (multiply) means multiplying frequency by n.

No.27 Encoder Prescale (0 Clear Position)

When attempting to set the coordinate value to 0 ° by using the multi-rotation stage and turning by 360°, this sets ‘the movement amount per one orbit – “1”(pulse)’.

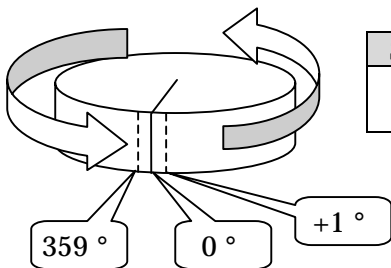

SYS No.	Setting Range	Description
27	0 to 16,777,215	Movement amount per one orbit – “1”(pulse)

No.28 Encoder Conversion Rounding Designation

When the conversion value for the encoder results in a decimal fraction, designates the digit to be rounded off.

【Example】 Setting: In case of 4 Conversion value is 0.00288888 0.003
 Setting: In case of 6 Conversion value is 0.00866666 0.00867

SYS No.	Setting Range	Description
28	0 to 9	Digit number right from decimal point. 0 is not rounded off.

No.29 Correction Setting

Sets implementation of feedback control. You can select feedback method either from implementing only once after movement is completed or continuing feedback after movement is completed.

SYS No.	Setting Range	Description
29	0	Not correct. Feedback (encoder correction) is not performed.
	1	Correct (only in positioning). After movement, encoder correction is performed once and completed.
	2	Correct (constant). After movement is completed, feedback continues.

 During implementation of feedback, the BUSY lamp on the front panel is lit even if the motor is suspended. However, BUSY flag is OFF in status response by feedback control.

No.30 Correction Permissible Range

No.31 Correction Retry Number

No.32 Correction Waiting Time

Completion conditions for correction are set. If correction is not completed within the set conditions, feedback is completed and an error (drive system error No.309) is returned.

SYS No.	Setting Range	Initial Setting	Description
30	1	1	Only the perfect matching. Pulse conversion value = Encoder conversion value
31	1 to 10,000	100	Set retry number
32	1 to 10,000	100	Set waiting time

No.33 Encoder Adding Direction

Increase and decrease polarity of counter value from encoder. That is, the rotating direction of the encoder.

SYS No.	Setting	Description
33	0	Normal
	1	Reverse: Positive and negative are reversed to setting 0.

No.34 Encoder Coordinate Synchronization

If this is set "1: executes", the encoder coordinate value together with pulse display value are simultaneously rewritten to ORG PRESET DATA in the case of completion of returning to origin.

SYS No.	Setting	Description
34	0	Does't execute Encoder Coordinate Synchronization
	1	executes Encoder Coordinate Synchronization

No.38 No.40 Selection of conversion display

About pulse count number (or encoder counter value) selection of display of conversion or display of non-conversion in coordinate display is performed.

SYS No.	Setting	Content
44	0: Non conversion display(pulse) 1: Conversion display(pulse)	Change in display on the first line
47	2: Non conversion display(encoder) 3: Conversion display(encoder)	Change in display on the second line

3-6. Backlash Correction

Backlash generated in the gear mechanism, etc., can be corrected.
 In order to carry out backlash correction, settings of corrected pulse amount and correcting method are required.

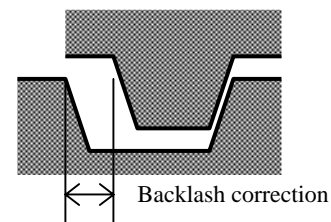

3-6-1. Remote control operation procedures

Set a correction amount with motor-related initial setting (the ASI command).

stxASI /h/ . . . **GRLF** Set with the 8th parameter.

For details, refer to the ASI command.

Designate a method by the parameter of each drive command (such as APS or RPS.)

3-6-2. Manual operation setting

In order to carry out backlash correction by manual operation, carry out necessary settings with SYS parameters in advance.

SYS No.	Setting	Content
7	0 to 16,777,215	Backlash correction pulse amount
8	0 to 4	Correction method

3-6-3. Backlash correction method

Executable backlash correction methods are as follows. The setting is common to remote control and manual operation.

Method	Description
0	Backlash correction invalid
1	When moving direction is changed from CCW to CW, reciprocating movement by correcting pulse amount is performed before moving.
2	When moving direction is changed from CW to CCW, reciprocating movement by correcting pulse amount is performed before moving.
3	After moving in the CCW direction, reciprocating movement by correcting pulse amount is performed.
4	After moving in the CW direction, reciprocating movement by correcting pulse amount is performed.

3-6-4. Details of correcting method

1		<p>When moving direction is changed from CCW to CW, reciprocating movement by the set correcting pulse amount is performed and then movement in the CW direction is performed. In this method, error by backlash is generated, however, the error amount is constant.</p>
2		<p>When moving direction is changed from CW to CCW, reciprocating movement by the set correcting pulse amount is performed and then movement in the CCW direction is performed. In this method, error by backlash is generated, however, the error amount is constant.</p>
3		<p>When moving in the CCW direction, at first, moving in the CCW direction, and reciprocating movement by the backlash correction amount is performed and then movement ends in the CW direction. With this method, lost motion caused by backlash is not generated because a stop is made on the determined gear surface side even when moving is performed from either the CW direction or CCW direction.</p>
4		<p>When moving in the CW direction, at first, moving in the CW direction, and reciprocating movement by the backlash correction amount is performed and then movement ends in the CW direction. With this method, lost motion caused by backlash is not generated because a stop is made on the determined gear surface side (opposite to 3) even when moving is performed from either the CW direction or CCW direction.</p>

In the above table, S represents a start position, (S2) represents a start position after backlash correction, and E represents a moving end position.

: Essentially drive
 : Correction drive

【Remarks】

In the case of methods 3 and 4, a slightly longer period of time is required to complete moving.

4. Part Names and Functions

4-1. Front Panel

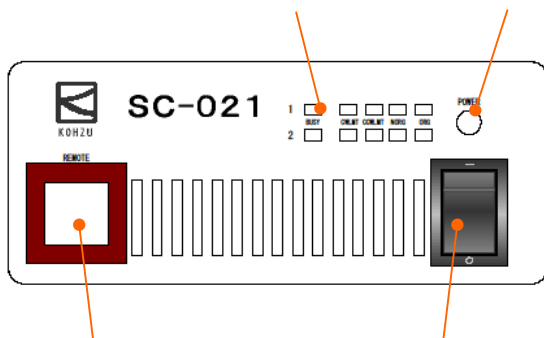

Limit and Position Sensor Display LED

Status of each position sensor and moving status is displayed.

Power lamp

Connector for Connecting Externally

The operation that is similar to Handy controller

Power Switch(SC-021)

Turns ON/OFF AC power.

4-2. リアパネル

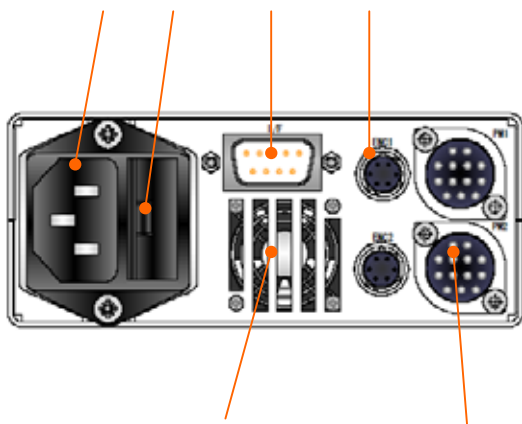

Power Supply Connector (3P type)

Input connector for 100V AC.

Fuse

Make sure to use a specified rated fuse.

Encoder Connecting Connector

Encoder signal input

RS-232C Connector

Connector 9 pins for RS-232C communications line

Fan



Never place an object behind the fan and obstruct exhaust.

Motor Connecting Connector

Stage driving output, sensor input

4-3. DIP Switch (RS-232C Setting Switch)

Conditions for RS-232C communications can be set and changed with the DIP switch (DSW3) on the main board of the main body.

Position of DIP switch

The DIP switch is located at the upper part of the main board on the main body.

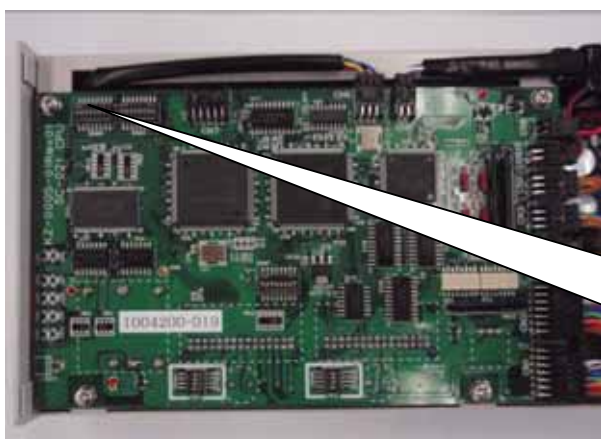

DSW3 is communication mode switch

 Don't change other switch

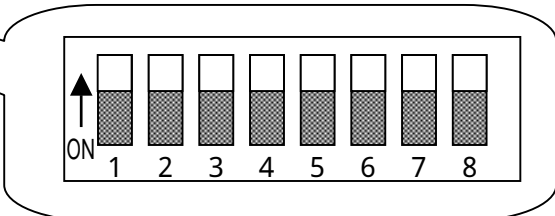

Settings

Settings are as in the table below.

Switch settings in the left half of the table are reflected in settings in the right half of the table.

Switch setting								Communication mode	RS-232C setting			
1	2	3	4	5	6	7	8		Speed	Parity	Word Length	Sbit
ON	ON	*	*	*	*	ON	ON	RS	38400	*	*	*
ON	ON	*	*	*	*	ON	OFF	RS	28800	*	*	*
ON	ON	*	*	*	*	OFF	ON	RS	19200	*	*	*
ON	ON	*	*	*	*	OFF	OFF	RS	9600	*	*	*
ON	ON	*	*	ON	ON	*	*	RS	*	NON	*	*
ON	ON	*	*	OFF	ON	*	*	RS	*	EVEN	*	*
ON	ON	*	*	OFF	OFF	*	*	RS	*	ODD	*	*
ON	ON	*	ON	*	*	*	*	RS	*	*	8	*
ON	ON	*	OFF	*	*	*	*	RS	*	*	7	*
ON	ON	ON	*	*	*	*	*	RS	*	*	*	1
ON	ON	OFF	*	*	*	*	*	RS	*	*	*	2

5. Remote Control

5-1. Remote Control

5-1-1. Transmission and Reception

The controller returns one response for one command.

The response timing varies according to the type of command or selection of response method.

Setting Command	The Commands such as MPC and ASI immediately return a response.
Drive Command	For drive-related commands, two types of response methods can be selected. (in RS-232C communications) 1. Returns a response after completion of operations. (Completion mode) 2. Returns a response immediately after receipt of the command, and confirms completion of operations by the STR command (Status Check). (Quick mode)
Information Request Command	These commands returns requested data.

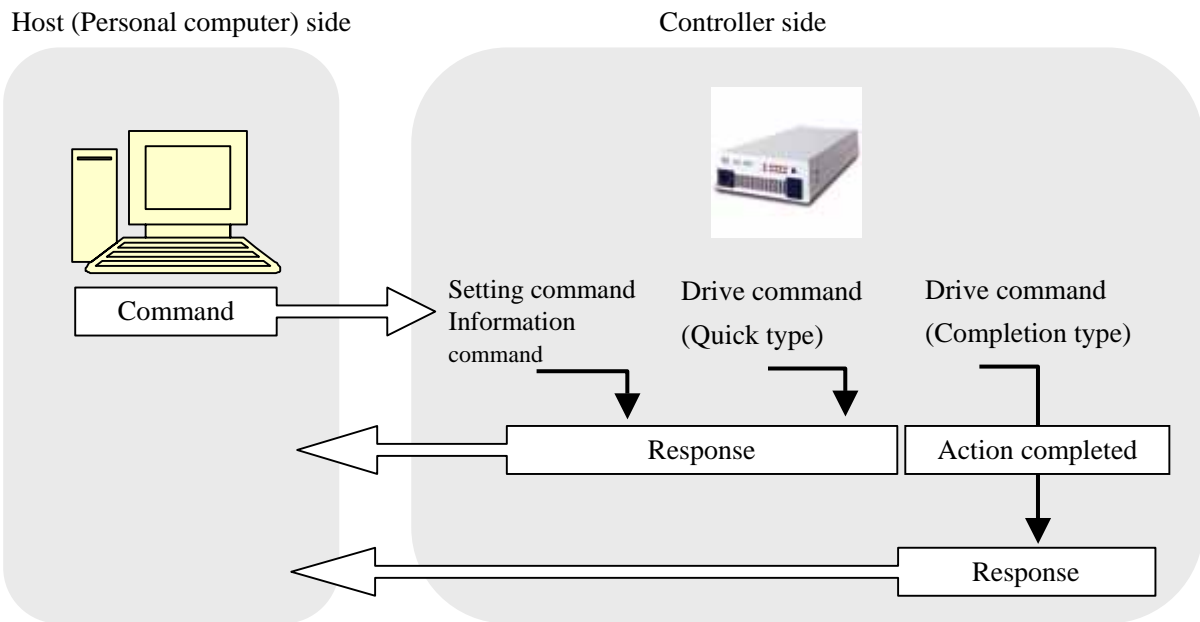

5-1-2. Remote Control Procedures

When you use / for the first time or when you change the settings, it is required to transmit setting command at the beginning of remote control procedures.

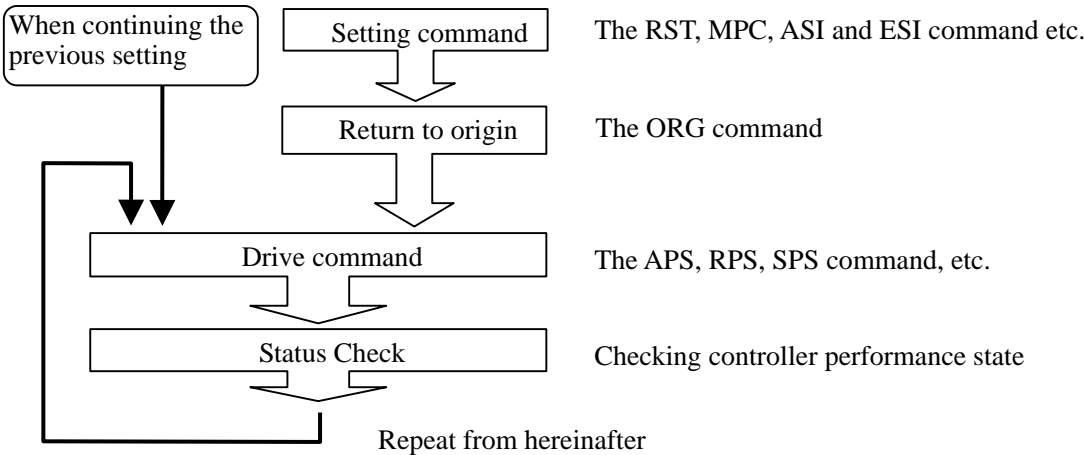

5-1-3. Command Format

One command consists of a header character (STX) and the command, parameters, and delimiter (CRLF).

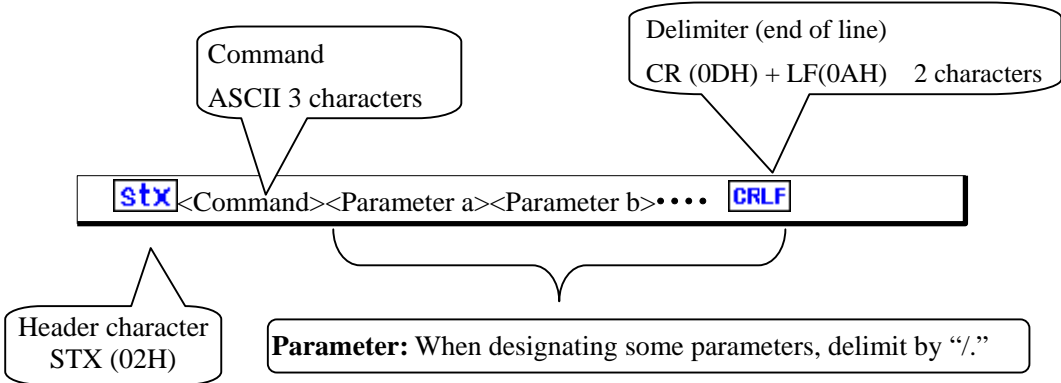

【Example】 Present position writing command: When you set pulse value of Axis No.2 to 1000

Sequence	1	2	3	4	5	6	7	8	9	10	11, 12
Command	stx	W	R	P	2	/	1	0	0	0	CRLF
Hexadecimal	02	57	52	50	32	2F	31	30	30	30	0D,0A

Characters which can be used in the command are numerical values (0 to 9), uppercase letters (A to Z), code (+, -) and symbol (/ , ?).

Space (20H) cannot be used in the command.

All parameters are required. Each parameter cannot be omitted.

5-1-4. Response

Format for response is as follows. When abnormality occurs, abnormal Response is returned. The response varies depending on each command, therefore, refer to the detailed page for each command.

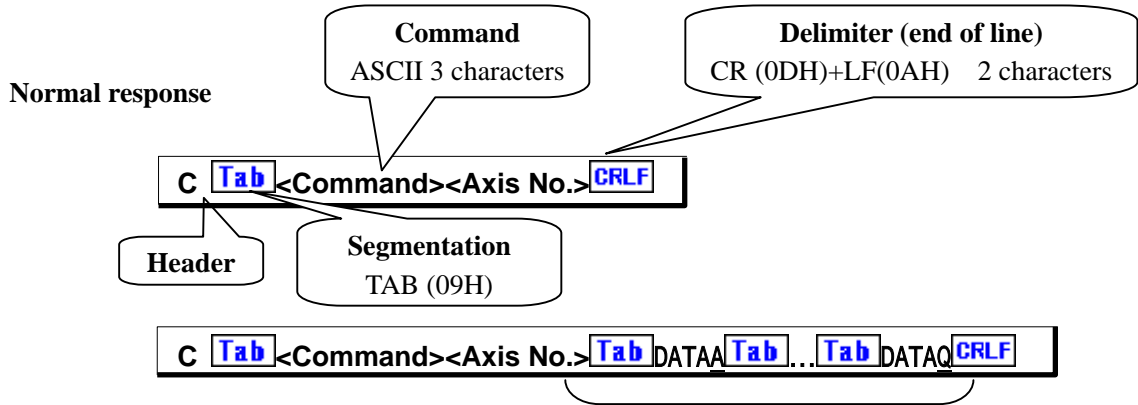

In a case where a plurality of these characters exist, these are segmented by TAB and sent.

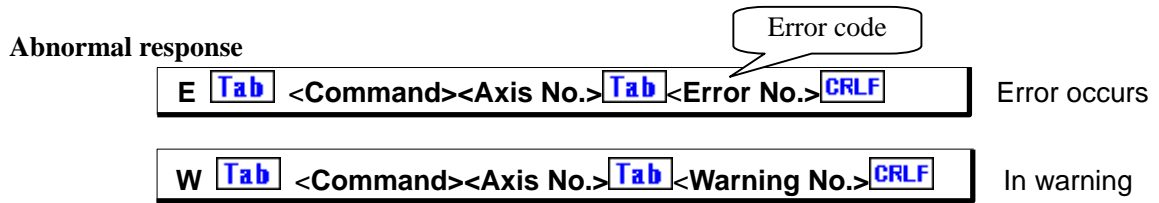

5-1-5. Characters Used

Characters described in the table below are characters which can be used in communications.

	0*	1*	2*	3*	4*	5*	6*	7*	8* to F*
*0	x	x	x	0	x	P	x	x	x
*1	x	x	x	1	A	Q	x	x	x
*2	stx	x	x	2	B	R	x	x	x
*3	x	x	x	3	C	S	x	x	x
*4	x	x	x	4	D	T	x	x	x
*5	x	x	x	5	E	U	x	x	x
*6	x	x	x	6	F	V	x	x	x
*7	x	x	x	7	G	W	x	x	x
*8	x	x	x	8	H	X	x	x	x
*9	Tab	x	x	9	I	Y	x	x	x
*A	LF	x	x	x	J	Z	x	x	x
*B	x	x	+	x	K	x	x	x	x
*C	x	x	x	x	L	x	x	x	x
*D	CR	x	-	x	M	x	x	x	x
*E	x	x	.	x	N	x	x	x	x
*F	x	x	/	?	O	x	x	x	x

 Small letters (a to z) aren't usable.

5-2. List of Commands

The commands that are usable in / are as in the table below.
For details, refer to the pages for respective commands.

Command		Page	
Type	Description / Function		
Settings	RST	System Reset	77
	MPC	Motor-related Polarity Change	66
	ASI	Motor-related Initial Setting (set acceleration and deceleration by time)	56
	MSI	Motor-related Initial Setting (set acceleration and deceleration with STEP)	56
	ESI	Encoder-related Initial Settings	62
	DSP	Display Switching	61
Drive	ORG	Origin Return Drive	68
	APS	Absolute Position Drive	55
	RPS	Relative Position Drive	76
	SPS	Linear Interpolate Drive	79
	MPS	Multi-axis Position Drive	67
	OSC	Oscillation Drive	69
	FRP	Free Rotation Drive	62
	STP	Stop	81
Coordinate	COF	ON/OFF for Excitation	60
	RDP	Position Read	72
	WRP	Position Write	85
	RDE	Encoder Read	70
	WRE	Encoder Write	83
	RDO	Offset Read	71
Information	WRO	Offset Write	84
	STR	Status Read	82
	RSY	System Setting Information Read	77
	RMS	Motor Setting Information Read	75
	RMP	MPC Setting Information Read	74
	RES	(ESI) Encoder Setting Information Read	73
Speed Table	IDN	Version Read	64
	WTB	Speed Table Setting Information Write	86
Teaching	RTB	Speed Table Setting Information Read	78
	TAS	Teaching Function Axis Information Set	87
	TMS	Teaching Function Position Information Set	88
	RDT	Teaching Function Position Data Read	90
	WRT	Teaching Function Position Data Write	90
	TPS	Teaching Function Teaching Drive Teaching	89

(To be continued to next page)

Commands that are usable in / are as in the table below. For details, refer to the pages for respective commands.
 (Continuance of previous page)

		Command		Page
Type	Description	Function		
Easy control (Internal setting dependence)	PMS	Easy Control	Speed Change	91
	PMP	Easy Control	Relative Position Drive	92
	PMA	Easy Control	Absolute Position Drive	93
	PMH	Easy Control	Origin Search	94
Drive aid	RCP	Constant Pulse Read		95
	WCP	Constant Pulse Write		95

6-3. Details of Commands

Details of each command are described below in alphabetical order.

A P S	<i>Absolute Position Drive</i>
--------------	--------------------------------

【Function】 Moves to a target position by controlling absolute position.

【Format】 `stx APSa/b/c/d/e/f/g/h CRLF`

Parameter = 8

Space between characters cannot be used.
Each parameter cannot be omitted.

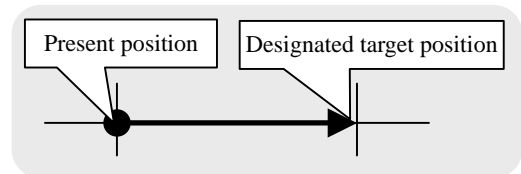

Command parameters

	Function	Setting	Remarks
a	Axis No.	1 to 2	
b	Accelerating and decelerating mode	1: Rectangular drive 2: Trapezoidal drive 3: Asymmetric trapezoidal drive 4: S-shaped drive 5: Asymmetric S-shaped drive	
c	Synchronizing mode	0: Invalid 1: Valid	Refer to the LNK command
d	Selection of speed table	0 to 9	
e	Moving target position	-68,108,813 to 68,108,813	1
f	Backlash correction	0: Invalid 1: CCW direction1 2: CW direction1 3: CW direction2 4: CCW direction2	Refer to the ASI command
g	Encoder correction	0: Invalid 1: Valid 2: Continue	Refer to the ESI command
h	Response method	0: Completed 1: Quick	

【Response】 Returns status information. Return timing varies depending on the response method.

Status	Response data
Normal	<code>C Tab APS< Axis No.> CRLF</code>
Abnormal	<code>W Tab APS< Axis No.> Tab <Warning No.> CRLF</code>
	<code>E Tab APS< Axis No.> Tab <Error No.> CRLF</code>

For <Error No.> and <Warning No.>, refer to the “ 6-4. Error Code. ”

【Example】

1.Moves No. 1 axis to a position of 10000 with trapezoidal drive.

`stx APS1/2/0/0/10000/0/0/0 CRLF`

2.Moves No. 2 axis to a position of -2000 with rectangular drive of speed table No.5 .

`stx APS2/1/0/5/-2000/0/0/0 CRLF`

【Remarks】

Carries out stop during driving with the stop command. → Refer to the STP command.

(Note) When the response method is “0: Completed”, no response is returned if stopped by the STP command.

1. Regarding to setting the target position, the amounts of the movement between the target position and the current position should be set up the value in a range from -16,777,215 to 16,777,215.

ASI MSI	<i>Motor-related Initial Setting</i>
--------------------	--------------------------------------

【Function】 Performs various settings to drive motor. For parameter details, refer to the next page and thereafter.

ASI = (Sets acceleration and deceleration by time)

MSI = (Sets acceleration and deceleration with STEP)

【Format】 **stx** ASI**a/b/c/d/e/f/g/h/i/j/k/l/m/n** **CRLF** Parameter = 14

【Format】 **stx** MSI**a/b/c/d/e/f/g/h/i/j/k/l/m/n** **CRLF** Parameter = 14

Space between characters cannot be used. Each parameter cannot be omitted.

Command parameters

	Function	Setting	Remarks	SYS
a	Axis No.	1 to 2		–
b	Start speed	1 to 4,095,500pps	Effective when designating the speed table No. 0 (Refer to “3-1. Speed Setting”)	1
c	Top speed	1 to 4,095,500pps		2
d	Accelerating time (ASI)	1 to 1,000,000 ×10ms		3
	Accelerating STEP (MSI)	1 to 1,000,000 STEP		
e	Decelerating time (ASI)	1 to 1,000,000 ×10ms		4
	Decelerating STEP (MSI)	1 to 1,000,000 STEP		
f	Position after detecting origin	-16,777,215 to 16,777,215		5
g	Prescale	0 to 16,777,215 pulse		6
h	Backlash correction	0 to 16,777,215 pulse		7
i	Motor pulse conversion Denominator	1 to 16,777,215		10
j	Motor pulse conversion Numerator	1 to 16,777,215		11
k	(Conversion: Trigonometric function)	0	Fixed to 0 Option	–
l	(Conversion: Distance from center)	0	Fixed to 0 Option	–
m	Designating rounding converted value	0 to 9		12
n	Stop method when detecting limit	0: Emergency stop (1: Decelerating stop)	Fixed to 0 in case of standard specifications	13

SYS in the above table is SYS No. in manual operations. Refer to “5-8. System Settings.”

【Response】 Returns status information. Returns immediately after receiving the command.

Status	Response data				
Normal	C	Tab	ASI <Axis No.>	CRLF	
	C	Tab	ASI <Axis No.>	CRLF	
Abnormal	E	Tab	ASI <Axis No.>	Tab	<Error No.> CRLF
	E	Tab	ASI <Axis No.>	Tab	<Error No.> CRLF

For <Error No.>, refer to the item of “6-4. Error Code.”

【Related】

The RMS Command Motor Setting Information Read

【Example】 When setting the same value as the default value on the No.2 axis, details of the parameter are as follows.

- When you use the ASI command

`stx`ASI2/500/5000/24/24/0/0/1/1/0/0/0/0`CRLF`

- When you use the MSI command

`stx`MSI2/500/5000/658/658/0/0/1/1/0/0/0/0`CRLF`

【Remarks】

 Note that if the limit stop method is set to “1: Deceleration” , the moving end limit is exceeded if the decelerating time is too long, whereby mechanical damage may occur. (Standard specification is fixed to “0: Emergency stop.”)

 Details that has been set is stored in the backup memory.

 When settings of the same item are changed by manual operation after setting by remote control, the details of the setting by manual operation is stored.

【Caution】

 Please note that a top speed up to 4,095,500 pps can be outputted, however, this does not mean that the motor and stage actually operate at that speed.

 Speed and other settings cannot be changed during driving.

ASI/MSI Command : Details of Parameter

b Start Speed

c Top Speed

d Accelerating Time/ STEP

e Decelerating Time/ STEP

Sets the start speed, top speed, accelerating time and decelerating time. Relationships among them are as in the figure on the right.

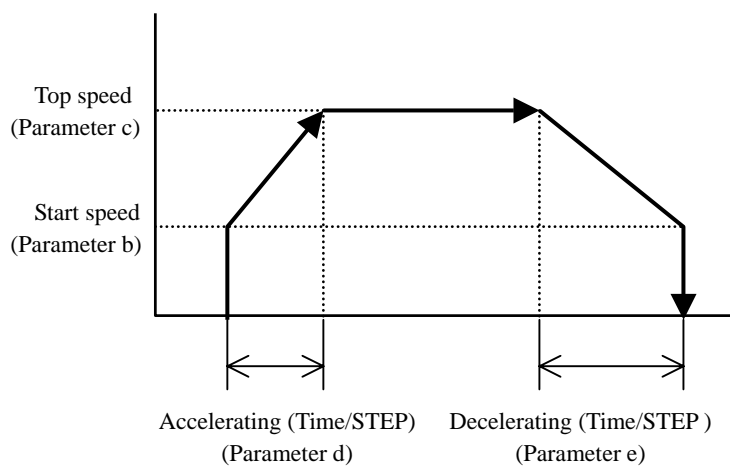

 This setting becomes effective when designating the speed table No. 0. In a case where designating the speed table No. 1 to 9, speed is driven with each table setting value.

f Position After Detecting Origin

Sets coordinate value (pulse amount) after origin detection (ORG) completed.
 (Example)When f=1000 was set, coordinate value of origin position becomes 1000 after returning to origin completed.

g Pre-Scale

When the pulse value exceeds the set coordinate value (pulse amount),it is automatically reset to 0.
 Set the value to “pulse of 1 rotation minus 1 pulse” when you use the multi-rotation stage.

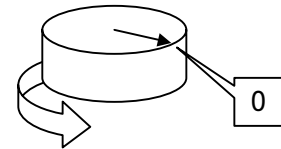

h Backlash Correction Pulse Number

Corrects backlash generated by gear mechanism.
 Implementation of backlash correction is set by a drive command (such as APS and RPS).

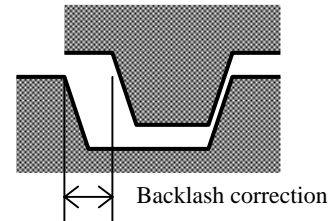

【Reference】

Backlash correction method is selected from the following methods in implementation.

Setting	Details
0	Backlash correction invalid
1	When moving direction is changed from CCW to CW, reciprocating movement by correcting pulse amount is performed before moving.
2	When moving direction is changed from CW to CCW, reciprocating movement by correcting pulse amount is performed before moving.
3	After moving in the CCW direction, reciprocating movement by correcting pulse amount is performed.
4	After moving in the CW direction, reciprocating movement by correcting pulse amount is performed.

i j Motor Pulse Conversion Numerator and Denominator

Defines the ratio to convert the output pulse value of the motor into the coordinate value(distance/angle).
 It is a coefficient when the conversion value is specified by conversion display or the RDP (position read) command.

k l Trigonometric Function and Distance From Center(Optional function)

 This function is not equipped with the standard-spec products. Normally set these parameters to 0.

m Motor Pulse Conversion Value Designating Digit to be Rounded off

When using the conversion function, designates the digit of conversion data to be rounded off.

n Stop Method When Detecting Limit

Defines the stop method when detecting the limit sensor at the moving end.
There are two methods as follows.

Setting	Stop method	
0	Emergency stop	Immediately stops at the position where limit sensor is detected.
1	Decelerating stop	Decelerates and stops. The decelerating time is the same as that of the decelerating setting in normal drive.

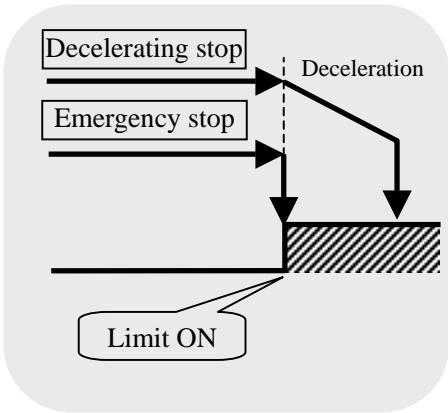

 In decelerating stop setting, attention must be paid because if the decelerating time is set to be long, the amount of overrun becomes large and a mechanical failure such as bumping to the moving end occurs.

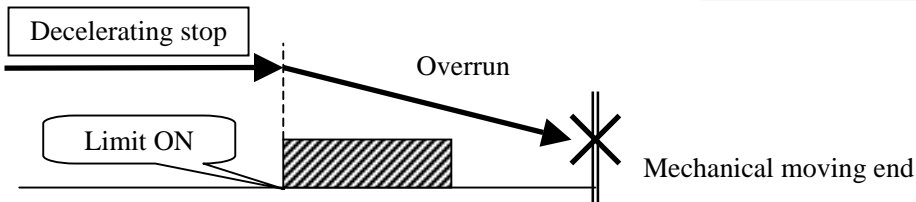

 With standard specifications, in order to eliminate the above trouble, “0: Emergency stop” becomes a fixed setting. If you would like to use in “1: Decelerating stop”, contact us for how to make a change in setting since a change can be made with internal setting.

COF	<i>ON/OFF for Excitation</i>
------------	------------------------------

【Function】 Switches ON/OFF for motor output current.

【Format】 `stx` **COF**a/b `CRLF` Parameter = 2

 Space between characters cannot be used. Each parameter cannot be omitted.

Command parameters

	Function	Setting	Remarks
a	Axis No.	1 to 2	
b	Excitation output switching	0, 1	0: Excitation ON 1: Excitation OFF

【Response】 Returns status information. Returns immediately after receiving the command.

Status	Response data
Normal	C <code>Tab</code> COF < Axis No.> <code>CRLF</code>
Abnormal	E <code>Tab</code> COF < Axis No.> <code>Tab</code> <Error No.> <code>CRLF</code>

For <Error No.>, refer to the item of "6-4. Error Code."

【Example】

 Error occurs if transmitting the drive-related command in a state of excitation OFF.
(Error code No.308)

 When using it for the Z axis, pay attention because falling off may occur when turning excitation OFF.

 When turning excitation OFF, the position may deviate because the motor becomes free. It is recommended to carry out origin return operations again after turning excitation ON.

 When turning off the power of the controller in the excitation OFF state and turning on the power again, the controller starts up in the excitation ON state.

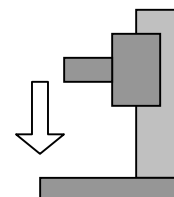

D S P *Display Switching*

【Function】 Switches description displayed on the controller front panel.

Function 1. Displayed axis No. switching

Switches axis No. displayed on the second and third lines from the liquid crystal display. Axis No. is displayed at the second character from the left.

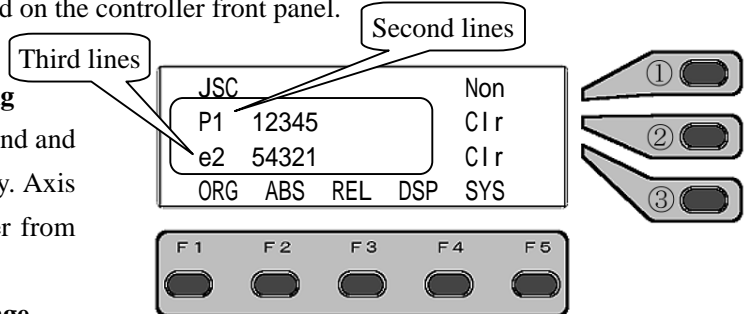

Function 2. Pulse/Encoder display change

Switches pulse value display and encoder counter value display. In the case of pulse display, “P” or “p” is displayed for the first character from the left, and in the case of encoder display, “E” or “e” is displayed.

Function 3. Conversion value, Non conversion value switching

Determines whether pulse and encoder counter values are directly displayed or conversion-displayed by the set coefficient. Panel displays are distinguished by capital or small letter such as “P” and “p”.

Meaning of displayed characters

P	Pulse display value (Non conversion value)	E	Encoder count value (Non conversion value)
p	Pulse display value (Conversion value)	e	Encoder count value (Conversion value)

【Format】 `stx DSPa/b/c CRLF` Parameter = 3

Space between characters cannot be used. Each parameter cannot be omitted.

Command parameters SYS is SYS No. in manual operations.

Function	Setting	Remarks	SYS
a Designating display line	1, 2	1: Second line 2: Third line	-
b Axis No.	1 to 2		37,39
c Selection of method	0, 1, 2, 3	0: Pulse value (Non conversion) 1: Encoder value (Non conversion) 2: Pulse value (Conversion) 3: Encoder value (Conversion)	43,44 46,47

【Response】 Returns status information. Returns immediately after receiving the command.

Status	Response data
Normal	C <code>Tab</code> DSP <Line No.> <code>CRLF</code>
Abnormal	E <code>Tab</code> DSP <Line No.> <code>Tab</code> <Error No.> <code>CRLF</code>

For <Error No.>, refer to the item of “6-4. Error Code.”

【Reference】 Pulse conversion setting (SYS No. 10 and 11), Encoder conversion setting (SYS No. 24 and 25)

【Remarks】

Details that has been set is stored in the backup memory.

When settings of the same item are changed by manual operation after setting by remote control, the details of the setting by manual operation is stored.

E S I	<i>Encoder-related Initial Settings</i>
--------------	---

【Function】 Performs initial setting when using the encoder.

- Setting when reading a value of the encoder and only displaying → Setting of format
- Setting when performing feedback control (supplement) with position data of encoder → Setting of format

【Format】

<table style="width: 100%; border-collapse: collapse;"> <tr> <td style="width: 10%; text-align: center;">stx</td> <td style="width: 40%;">ESla/b/c/d/e/f/g</td> <td style="width: 10%; text-align: center;">CRLF</td> <td style="width: 30%;">..... Reading out encoder value</td> <td style="width: 10%; text-align: right;">Parameter = 7</td> </tr> <tr> <td style="text-align: center;">stx</td> <td>ESla/b/c/d/e/f/g/h/i/j/k</td> <td style="text-align: center;">CRLF</td> <td>..... Performing encoder correction</td> <td style="text-align: right;">= 11</td> </tr> </table>	stx	ESla/b/c/d/e/f/g	CRLF Reading out encoder value	Parameter = 7	stx	ESla/b/c/d/e/f/g/h/i/j/k	CRLF Performing encoder correction	= 11
stx	ESla/b/c/d/e/f/g	CRLF Reading out encoder value	Parameter = 7						
stx	ESla/b/c/d/e/f/g/h/i/j/k	CRLF Performing encoder correction	= 11						

Space between characters cannot be used. Each parameter cannot be omitted.

Command parameters

Function		Setting	Remarks	SYS
a	Axis No.	1 to 2		-
b	N.C	0	Fixed to 0	-
c	Encoder conversion Denominator	1 to 16,777,215		24
d	Encoder conversion Numerator	1 to 16,777,215		25
e	Pre-scale	0 to 16,777,215		27
f	Multiplication	1, 2, 4-fold		26
g	Encoder polarity change	0: Normal 1: Reverse		33
h	Retry number	1 to 10,000 times		31
i	Permissible stop range	1		30
j	Waiting time	1 to 10,000	msec	32
k	Conversion designating rounding	0 to 9 digits	Refer to the RDE command	28

SYS in the above table is SYS No. in manual operations. Refer to “5-8. System Setting.”

【Response】 Returns status information. Returns immediately after receiving the command.

Status	Response data			
Normal	C	Tab	ESl<Axis No.>	CRLF
Abnormal	E	Tab	ESl<Axis No.>	Tab <Error No.> CRLF

For <Error No.>, refer to the item of “6-4. Error Code.”

【Remarks】



If this command is issued, the present encoder data is rewritten.



Details that has been set is stored in the backup memory.



When settings of the same item are changed by manual operation after setting by remote control, the details of the setting by manual operation is stored.

F R P	<i>Free Rotation Drive</i>
--------------	----------------------------

【Function】 Continuous drive is carried out until the stop command (STP) is issued.

【Format】 **stx** FRPa**/b/c/d/e/f** **CRLF** Parameter = 6



Space between characters cannot be used. Each parameter cannot be omitted.

Command parameters

	Function	Setting	Remarks
a	Axis No.	1 to 2	
b	Accelerating and decelerating mode	1: Rectangular drive 2: Trapezoidal drive 3: Asymmetric trapezoidal drive 4: S-shaped drive 5: Asymmetric S-shaped drive	
c	Synchronizing mode	0: Invalid 1: Valid	Refer to the LNK command
d	Selection of speed table	0 to 9	
e	Rotational direction	1: CW direction 0: CCW direction	
f	Response method	0: Completed 1: Quick	

【Response】 Returns status information. Return timing varies depending on the response method.

Status	Response data
Normal	C Tab APS< Axis No.> CRLF
Abnormal	W Tab APS< Axis No.> Tab <Warning No.> CRLF
	E Tab APS< Axis No.> Tab <Error No.> CRLF

For <Error No.> and <Warning No.>, refer to the " 6-4. Error Code. "

【Example】

1. Continuously rotates the No. 1 axis in the CW direction by trapezoidal drive.

stx FRP1/2/0/0/1/0 **CRLF**

【Remarks】

Carries out stop during driving with the stop command. → Refer to the STP command.

(Note) When the response method is 0: completed, no response is returned if stopped by the STP command.

IDN	<i>Version Read</i>
------------	---------------------

【Function】 Responds with the model name of the controller body and the version of the system program.

【Format】 stx IDN CRLF Parameter = 0

【Response】 C Tab IDN0 Tab <Model name> Tab <Version> CRLF

【Example of Response】 C Tab IDN0 Tab 210 Tab 1000 CRLF “ Ver1.000”

【Example of Response】 C Tab IDN0 Tab 410 Tab 1000 CRLF “ Ver1.000”

MEMO

M P C	<i>Motor related Polarity Change</i>
--------------	--------------------------------------

【Function】 Changes and sets rotating direction of the motor and input logic of each sensor such as limit and origin.

Motor rotating direction
Sets actual rotating direction to rotating command.

Sensor input logic
Sets logic (N.C, N.O) in agreement with the connected sensor.

CW, CCW swap
Electrically switches effective limit sensor for moving direction.

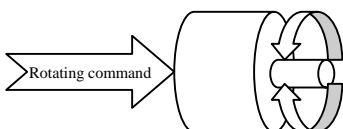

【Format】 **stx** MPC**a/b/c/d/e/f/g** **CRLF** Parameter = 7

Space between characters cannot be used. Each parameter cannot be omitted.

Command Parameters

	Function	Setting range	Remark
a	Designating axis	1 to 2	
b	Motor rotating direction	0: Forward rotation 1: Reverse rotation	
c	CW limit sensor	0: Positive 1: Negative	
d	CCW limit sensor	0: Positive 1: Negative	
e	NORG sensor	0: Positive 1: Negative	
f	ORG sensor	0: Positive 1: Negative	
g	CW, CCW swap	0: Positive 1: Negative	

【Response】 Returns status information. Return timing depends on the response method.

Status	Response data
Normal	C Tab MPC <Axis No.> CRLF
Abnormal	E Tab MPC <Axis No.> Tab <Error No.> CRLF

For <Error No.>, refer to the item of “6-4. Error Code.”

【Related】

The RMP command MPC setting information read

【Remarks】

Details that has been set is stored in the backup memory.

When settings of the same item are changed by manual operation after setting by remote control, the details of the setting by manual operation is stored.

MPS	<i>Multi-axis Position Drive</i>
------------	----------------------------------

【Function】 Performs simultaneous drive of 2 axes.

【Explanation】 In general, periods of time required for movement differ and loci are depicted as shown by the broken line as in the right handed figure, if the moving distance and moving speed differ from each other in the 2 axes simultaneous drive. However, if the linear interpolation (SPS) command is designated, the speeds of the respective axes are automatically calculated.

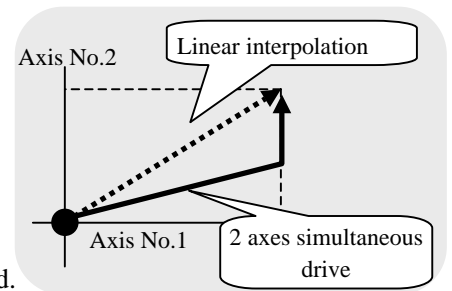

【Format】 Designating 2 axes `stx`MPSa/b/c/d/e`CRLF` Parameter = 5

Space between characters cannot be used. Each parameter cannot be omitted.

Command parameters

	Function	Setting	Remarks
a	1st axis No.	1 to 2	
b	1st axis target position	-68,108,813 to 68,108,813	1
c	2nd axis No.	1 to 2	
d	2nd axis target position	-68,108,813 to 68,108,813	1
e	Response method	0: Completed 1: Quick	

【Response】 Returns status information. Return timing depends on the response method.

Status	Response data
Normal	<code>C</code> <code>Tab</code> APS< First Axis No.> <code>CRLF</code>
Abnormal	<code>W</code> <code>Tab</code> APS< First Axis No.> <code>Tab</code> <Warning No.> <code>CRLF</code>
	<code>E</code> <code>Tab</code> APS< First Axis No.> <code>Tab</code> <Error No.> <code>CRLF</code>

For <Error No.> and <Warning No.>, refer to the " 6-4. Error Code. "

【Example】 When simultaneously driving with the MPS command for No. 1 to No. 2 axes

1. Sets the drive condition by setting the target positions of No. 1 to No. 2 axes to ?. (Type ? character)
 - `stx` APS1/2/0/0/?/0/0/0 `CRLF`
 - `stx` APS2/2/0/0/?/0/0/0 `CRLF`
2. Sets No.1 axis to the target position 1000, No.2 axis to the target position 2000,
 - `stx` MPS1/1000/2/2000/0 `CRLF`

【Remarks】

The content set in APS ? is stored in the backup memory as MPS data.

1. Regarding to setting the target position, the amounts of the movement between the target position and the current position should be set up the value of the range from -16,777,215 to 16,777,215.

ORG	<i>Origin Return Drive</i>
------------	----------------------------

【Function】 Performs origin position detection according to the selected method. For return to origin, 14 methods can be selected. For details, refer to “3-3. Origin Return Method.”

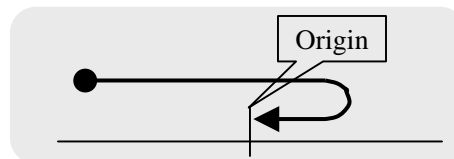

【Format】 **stx** **ORG***a/b/c/d/e/f* **CRLF** Parameter = 6

Space between characters cannot be used. Each parameter cannot be omitted.

Command parameters

	Function	Setting	Remarks
a	Axis No.	1 to 2	
b	Accelerating and decelerating mode	1: Rectangular drive 2: Trapezoidal drive 3: Asymmetric trapezoidal drive 4: S-shaped drive 5: Asymmetric S-shaped drive	
c	Synchronizing mode	0: Invalid 1: Valid	Refer to the LNK command
d	Speed table selection	0 to 9	
e	Origin return method selection	1 to 14	Refer to “3-3. Origin Return Method”
f	Response method	0: Completed 1: Quick	

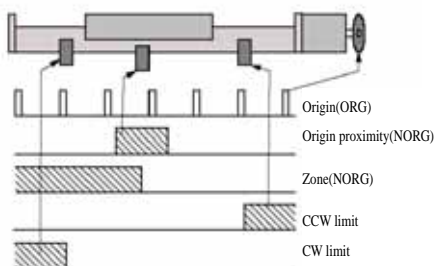

Sensor configuration

Method	Sensor configuration	Description
1	S1, S3	Returning direction is determined with zone sensor NORG(S3) and detects origin ORG(S1).
2	S3	Returning direction is determined with zone sensor NORG(S3) and set the edge of the zone sensor NORG(S3) the origin position.
3	S1, S2, L-	ORG(S1) located in NORG (S2) is origin position.
4	S2, L-	NORG (S2) sensor located in moving zone is set to be the origin position.
5	S1, L+	Origin sensor ORG(S1) in proximity of CW limit(L+) is set to be the origin position.
6	S1, L-	Origin sensor in proximity of CCW limit(L-) is set to be the origin position.
7	L+	Edge of CW limit(L+) is set to be the origin position.
8	L-	Edge of CCW limit(L-) is set to be the origin position.
9	S1	ORG (S1) sensor located in moving zone is set to be the origin position.
10	Non	Present position is set to be the origin position. (stage doesn't move.)
11	S1, L+	After the origin position is detected by method 5, and moved by the set amount, this position is set to be the origin.
12	S1, L-	After the origin position is detected by method 6, and moved by the set amount, this position is set to be the origin.
13	L+	After the origin position is detected by method 7, and moved by the set amount, this position is set to be the origin.
14	L-	After the origin position is detected by method 7, and moved by the set amount, this position is set to be the origin.

【Response】 Returns status information. Return timing depends on the response method.

Status	Response data
Normal	C Tab ORG <Axis No.> CRLF
Abnormal	E Tab ORG <Axis No.> Tab <Error No.> CRLF

For <Error No.>, refer to the item of “6-4. Error Code.”

【Remarks】

Speed setting of manual operation is not changed by speed setting of the ORG command.

OSC	<i>Oscillation Drive</i>
------------	--------------------------

【Function】 Performs oscillation drive between the present position and the position specified by movement amount.

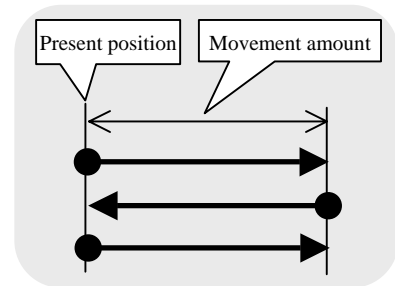

【Format】 `stx OSCa/b/c/d/e/f/g/h/i/j/k CRLF`

Parameter = 11

Space between characters cannot be used.
Each parameter cannot be omitted.

Command parameters

	Function	Setting	Remarks
a	Axis No.	1 to 2	
b	Accelerating and decelerating mode	1: Rectangular drive 2: Trapezoidal drive 3: Asymmetric trapezoidal drive 4: S-shaped drive 5: Asymmetric S-shaped drive	
c	Synchronizing mode	0: Invalid 1: Valid	Refer to the LNK command
d	Selection of speed table	0 to 9	
e	Oscillating direction	0: CCW 1: CW	
f	Movement amount	-16,777,215 to 16,777,215	
g	Oscillating times	1 to 65,534	One reciprocation by 2 times
h	Stop time	0 to 65,534	× 1msec
i	Shutter synchronization	0: Invalid 1: Valid	1
j	Backlash correction	0: Invalid 1: CW direction1 2: CCW direction1 3: CCW direction2 4: CW direction2	Refer to the ASI command
k	Response method	0: Completed 1: Quick	

【Response】 Returns status information. Return timing varies depending on the response method.

Status	Response data
Normal	<code>C Tab OSC <Axis No.> CRLF</code>
Abnormal	<code>W Tab OSC <Axis No.> Tab <Warning No.> CRLF</code>
	<code>E Tab OSC <Axis No.> Tab <Error No.> CRLF</code>

For <Error No.> and <Warning No.>, refer to the "6-4. Error Code."

【Example】

Performs 5 reciprocations of the No. 1 axis between the present position and the position that are 10000 pulses away from the present position.
(Stop time when reversing: 0.1 seconds)

`stx OSC1/2/0/0/10000/10/100/0/0/0 CRLF`

【Remarks】

- Carry out a stop during driving by the stop (STP) command. Refer to the STP command.
(Note) When the Response method is 0: completed, no response is returned if stopped by the STP command.
- The present oscillating times can be known with the STR command.
- 1. In , the shutter synchronization can use only "0: invalidity".
When "1: effective" is transmitted shutter synchronously with , error code 700 is answered.

RDE	<i>Encoder Read</i>
------------	---------------------

【Function】 Responds with the counter value of the connected encoder input.

【Format】 **stx** RDE**a/b** **CRLF** Parameter = 2

 Space between characters cannot be used. Each parameter cannot be omitted.

Command parameters

	Function	Setting	Remarks
a	Axis No.	1 to 2	
b	Mode	0: Pulse 1: Pulse + Offset 2: Conversion value 3: Conversion value + Offset	

【Response】 Returns counter value.

Status	Response data
Normal	C Tab RDE <Axis No.> Tab <Counter value> CRLF
Abnormal	E Tab RDE <Axis No.> Tab <Error No.> CRLF

For <Error No.>, refer to the item of "6-4. Error Code."

【Example】 Reads the second encoder value.

Command: **stx** RDE**2/0** **CRLF**

Response: **C** **Tab** RDE**2****Tab**-**2000****CRLF**

【Related】

The ESI command Initial setting of the encoder

R D O	<i>Offset Read</i>
--------------	--------------------

【Function】 Responds with the present set offset.

【Format】 **stx** RDO**a** **CRLF** Parameter = 1



Space between characters cannot be used. Each parameter cannot be omitted.

Command parameters

	Function	Setting	Remarks
a	Axis No.	1 to 2	

【Response】 Returns an offset value.

Status	Response data			
Normal	C	Tab	RDO<Axis No.>	Tab <Offset value> CRLF
Abnormal	E	Tab	RDO<Axis No.>	Tab <Error No.> CRLF

For <Error No.>, refer to the item of “6-4. Error Code.”

【Example】 Reads the offset value of axis No.1.

Command: **stx** RDO1 **CRLF**

Response: **C** **Tab** RDO1 **Tab** 100 **CRLF**

RDP	<i>Position Read</i>
------------	----------------------

【Function】 Responds with the present position information (counter value).

【Format】 stx RDPa**u**b CRLF Parameter = 2

Space between characters cannot be used. Each parameter cannot be omitted.

Command parameters

	Function	Setting	Remarks
a	Axis No.	1 to 2	
b	Mode	0: Pulse 1: Pulse + Offset 2: Conversion value 3: Conversion value + Offset	

【Response】 Returns the counter value.

Status	Response data
Normal	C Tab RDP <Axis No.> Tab <Counter value> CRLF
Abnormal	E Tab RDP <Axis No.> Tab <Error No.> CRLF

For <Error No.>, refer to the item of "6-4. Error Code."

【Example】 Reads the coordinate value of axis No.2.

Command: stx RDP2/0 CRLF

Response: C Tab RDP2Tab123456CRLF

R E S	(ESI) Encoder Setting Information Read
--------------	---

【Function】 Responds with present encoder setting information set by the ESI command.

【Format】 **stx** RES**a** **CRLF** Parameter = 1

Space between characters cannot be used. Each parameter cannot be omitted.

Command parameters

	Function	Setting	Remarks
a	Axis No.	1 to 2	

【Response】 Returns encoder setting information.

Plural parameters are returned being sandwiched in the Tab codes.

Status	Response Data
Normal	C Tab RES A Tab ... Tab K CRLF
Abnormal	E Tab RES<Axis No.> Tab <Error No.> CRLF

For <Error No.>, refer to the item of “6-4. Error Code.”

【Response data】

	Item	Status	Remarks
A	Axis No.	1 to 2	
B	N.C	0	Fixed to 0
C	Encoder conversion Denominator	1 to 16,777,215	
D	Encoder conversion Numerator	1 to 16,777,215	
E	Pre-scale	0 to 16,777,215	
F	Multiplication	1、 2、 4	
G	Encoder polarity change	0: Normal 1: Reverse	
H	Retry number	1 to 10,000	
I	Permissible stop range	1	
J	Waiting time	1 to 10,000	msec
K	Conversion Designating rounding	0 to 9	Refer to the RDE command

【Example】 Reads the setting of axis No.2.

Command: **stx**RES**2****CRLF**

Response: **C** Tab RES**2** Tab **0** Tab **1** Tab **1** Tab **0** Tab **1** Tab **0** Tab **10** Tab **1** Tab **10** Tab **0** **CRLF**

【Related】

The ESI Command Initial settings of the encoder

RMP	<i>MPC Setting Information Read</i>
------------	-------------------------------------

【Function】 Responds with present motor related polarity setting information set by the MPC command.

【Format】 **stx** **RMP****a** **CRLF** Parameter = 1

Space between characters cannot be used. Each parameter cannot be omitted.

Command parameters

	Function	Setting	Remarks
a	Axis No.	1 to 2	

【Response】 Returns motor related polarity setting information.

Plural parameters are returned being sandwiched in the Tab codes.

Status	Response Data
Normal	C Tab RMP A Tab B Tab ... Tab G CRLF
Abnormal	E Tab RMP <Axis No.> Tab <Error No.> CRLF

For <Error No.>, refer to the item of “6-4. Error Code.”

【Response data】

	Item	Status	Remarks
A	Axis No.	1 to 2	
B	Motor rotating direction	0: Forward rotation 1: Reverse rotation	
C	CW limit sensor	0: Positive 1: Negative	
D	CCW limit sensor	0: Positive 1: Negative	
E	NORG sensor	0: Positive 1: Negative	
F	ORG sensor	0: Positive 1: Negative	
G	CW, CCW swap	0: Positive 1: Negative	

【Example】 Reads setting of No. 1 axis.

Command: **stx**RMP1**CRLF**

Response: **C** Tab RMP1 Tab 0 Tab 1 Tab 1 Tab 0 Tab 1 Tab 0 **CRLF**

【Related】

The MPC command Motor related polarity setting

RMS	<i>Motor Setting Information Read</i>
------------	---------------------------------------

【Function】 Responds with present motor related initial setting information set by the ASI and MSI commands.

【Format】 **stx** **RMSa** **CRLF** Parameter =1

 Space between characters cannot be used. Each parameter cannot be omitted.

Command parameters

	Function	Setting	Remarks
a	Axis No.	1 to 2	

【Response】 Returns motor related initial setting information.

Plural parameters are returned being sandwiched in the Tab codes.

Status	Response Data
Normal	C Tab RMS A Tab B Tab ... Tab Q CRLF
Abnormal	E Tab RMS <Axis No.> Tab <Error No.> CRLF

For <Error No.>, refer to the item of “6-4. Error Code.”

【Response data】

	Item	Status	Remarks
A	Axis No.	1 to 2	
B	Start speed	1 to 4,095,500 pps	Setting value of speed table No. 0 (Refer to “3-1. Speed setting”)
C	Top speed	1 to 4,095,500 pps	
D	Accelerating pulse number	0 to 1,000,000 pulse	
E	Decelerating pulse number	0 to 1,000,000 pulse	
F	Position after detecting origin	-16,777,215 to 16,777,215	
G	Pre-scale	0 to 16,777,215 pulse	
H	Backlash correction	0 to 16,777,215 pulse	
I	Motor pulse conversion Denominator	0 to 16,777,215	
J	Motor pulse conversion Numerator	1 to 16,777,215	
K	(Conversion Trigonometric function)	0	Option
L	(Conversion Distance from center)	0	Option
M	Designating rounding off converted value	0 to 9	
N	Stop method when detecting limit	0: Emergency stop (1: Decelerating stop)	Fixed to 0 for standard specification
O	Accelerating time	1 to 1,000,000	× 10msec
P	Decelerating time	1 to 1,000,000	
Q	Rectangular driving speed	1 to 4,095,500	pps SC controller Ver.3.00 or more

【Related】

The ASI Command、 the MSI Command Motor Related Initial Setting
The RSI Command Rectangular Drive Speed

R P S	<i>Relative Position Drive</i>
--------------	--------------------------------

【Function】 Moves from the present position to a position by a set movement amount.

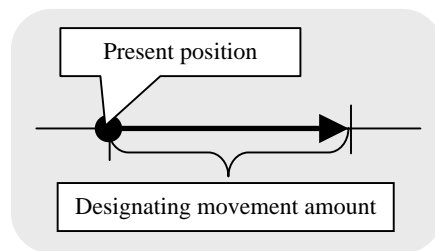

【Format】 `stx RPSa/b/c/d/e/f/g/h CRLF`

Parameter = 8



Space between characters cannot be used. Each parameter cannot be omitted.

Command parameters

	Function	Setting	Remarks
a	Axis No.	1 to 2	
b	Accelerating and decelerating mode	1: Rectangular drive 2: Trapezoidal drive 3: Asymmetric trapezoidal drive 4: S-shaped drive 5: Asymmetric S-shaped drive	
c	Synchronizing mode	0: Invalid 1: Valid	Refer to the LNK command
d	Selection of speed table	0 to 9	
e	Movement amount	-16,777,215 to 16,777,215	
f	Backlash correction	0: Invalid 1: CW direction1 2: CCW direction1 3: CCW direction2 4: CW direction2	Refer to the ASI command
g	Encoder correction	0: Invalid 1: Valid 2: Continue	Refer to the ESI command
h	Response method	0: Completed 1: Quick	

【Response】 Returns status information. Return timing depends on the response method.

Status	Response data
Normal	<code>C Tab RPS<Axis No.> CRLF</code>
Abnormal	<code>W Tab RPS<Axis No.> Tab <Warning No.> CRLF</code>
	<code>E Tab RPS<Axis No.> Tab <Error No.> CRLF</code>

For <Error No.> and <Warning No.>, refer to the " 6-4. Error Code. "

【Example】

1. Moves No. 1 axis with trapezoidal drive by 1000 pulses.

`stx RPS1/2/0/0/1000/0/0/0 CRLF`

2. Moves No. 2 axis in negative direction by 2000 pulses with rectangular drive of speed table No.5.

`stx RPS2/1/0/5/-2000/0/0/0 CRLF`

【Remarks】



Carried out a stop during driving by the stop (STP) command. Refer to the STP command.

(Note) When the response method is 0: completed, no response is returned if stopped by the STP command.



The RPS command exerts no influence on setting of relative movement amount /speed table No.(REL) in manual operation.

R S T	<i>System Reset</i>
--------------	---------------------

【Function】 Resets all settings in the controller to the initial status (settings when shipping from the factory).

【Format】 `stx` RST `CRLF` Parameter = 0

Space cannot be used in the command sentence.

【Response】 Returns status information.

Status	Response data
Normal	C <code>Tab</code> RST <code>CRLF</code>
Abnormal	E <code>Tab</code> RST <code>Tab</code> <Error No.> <code>CRLF</code>

For <Error No.>, refer to the item of “6-4. Error Code.”

【Remarks】

About 60 ms is required to complete (response) the reset after transmitting the RST command.

R S Y	<i>System Setting Information Read</i>
--------------	--

【Function】 Reads the present set value of the system setting parameters.
For system setting, refer to the “5-8-1. List of System Settings.”

【Format】 `stx` RSY`a/b` `CRLF` Parameter = 2

Space between characters cannot be used. Each parameter cannot be omitted.

Command parameters

	Function	Setting	Remarks
<u>a</u>	Axis No.	1 to 2	
<u>b</u>	SYS No.	1 to 47	

【Response】 Returns set value.

Status	Response data
Normal	C <code>Tab</code> RSY<Axis No.> <code>Tab</code> <SYS No.> <code>Tab</code> <Set value> <code>CRLF</code>
Abnormal	E <code>Tab</code> RSY<Axis No.> <code>Tab</code> <Error No.> <code>CRLF</code>

For <Error No.>, refer to the item of “6-4. Error Code.”

【Example】

1. Check the excitation output status ON/OFF of No. 1 axis.
`stx` RSY1/21 `CRLF` -> C `Tab` RSY1 `Tab` 21 `Tab` 0 `CRLF` ... Excitation ON
2. Check the origin return method of No. 2 axis.
`stx` RSY2/9 `CRLF` -> C `Tab` RSY2 `Tab` 9 `Tab` 3 `CRLF` ... Setting 3

R T B	<i>Speed Table Setting Information Read</i>
--------------	---

【Function】 Reads the present set value in the speed table.

【Format】 **stx** RTB**a/b** **CRLF** Parameter = 2

Space between characters cannot be used. Each parameter cannot be omitted.

Command parameters

	Function	Setting	Remarks
a	Axis No.	1 to 2	
b	Speed table No.	1 to 11	

Speed table No.1-9 are used for drive commands in remote control, origin return drive, absolute position movement and relative position movement in manual operations.

Speed table No. 10 and 11 are speed for joystick operation in manual operations. No. 10 is the setting in high speed operations, and No. 11 is the setting in low speed operations.

【Response】 Returns set value. Returns immediately after receiving the command.

Status	Response data
Normal	C Tab RTB A Tab B Tab ... Tab J CRLF
Abnormal	E Tab RTB <Axis No.> Tab <Error No.> CRLF

For <Error No.>, refer to the item of “6-4. Error Code.”

【Response data】

	Item	Status	Remarks
A	Axis No.	1 to 2	
B	Speed table No.	1 to 11	1 - 9: For drive system 10, 11: Joystick operation speed
C	Setting method check	0:MSI 1 : ASI	1
D	Start speed	1 to 4,095,500	pps
E	Top speed	1 to 4,095,500	pps
F	Accelerating pulse number	1 to 1,000,000	Pulse
G	Decelerating pulse number	1 to 1,000,000	Pulse
H	Accelerating time	1 to 1,000,000	× 10ms
I	Decelerating time	1 to 1,000,000	× 10ms
J	Rectangular drive speed	1 to 4,095,500	pps SC Controller Ver.3.00 or more

1 Returns command type (MSI or ASI) used for motor setting.

【Reference】

The WTB command, the RSI command

S P S	<i>Linear Interpolate Drive</i>
--------------	---------------------------------

【Function】 Performs linear interpolation in simultaneous drive of 2 axes.

【Description】 In general 2 axes simultaneous drive, if the moving distances or moving speeds of the axes are different from each other, the time period required to move also differs as shown by the broken line in the figure on the right, however, if linear interpolation is designated, the velocities of respective axes are automatically calculated and respective axes move linearly.

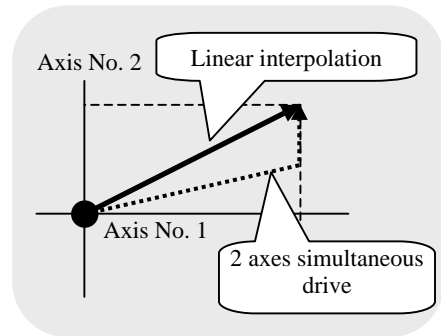

【Format】

Designating 2 axes stxSPSa/b/c/d/e/f/g/h/i/j CRLF Parameter =10



Space between characters cannot be used. Each parameter cannot be omitted.

- The speed of other axes is decided based on the speed of the first axis, and note the overspeed, please when driving distance of the first axis is more extremely shorter than that of other axes.

Command parameters

	Function	Setting	Remarks
a	1st axis No.	1 to 2	Varies according to model
b	1st axis target position	-68,108,813 to 68,108,813	1
c	2nd axis No.	1 to 2	Varies according to model
d	2nd axis target position	-68,108,813 to 68,108,813	1
e	Accelerating and decelerating mode	1: Rectangular drive 2: Trapezoidal drive 3: Asymmetric trapezoidal drive 4: S-shaped drive 5: Asymmetric S-shaped drive	
f	Speed table selection	0 to 9	
g	1st axis encoder correction	0: Invalid 1: Valid 2: Continue	Refer to the ESI command
h	2nd axis encoder correction	0: Invalid 1: Valid 2: Continue	
i	Backlash correction	0: Invalid 1: CW direction1 2: CCW direction1 3: CCW direction2 4: CW direction2	Refer to the ASI command
j	Response method	0: Completed 1: Quick	

1. Regarding to setting the target position, the amounts of the movement between the target position and the current position should be set up the value of the range from -16,777,215 to 16,777,215.

【Response】 Returns status information. Return timing depends on the response method.

Status	Response data	
Normal	C	Tab SPS<First Axis No>CRLF
Abnormal	W	Tab SPS< First Axis No >Tab <Warning No.> CRLF
	E	Tab SPS< First Axis No >Tab <Error No.> CRLF

For the <Error No.> and <Warning No.>, refer to the “ 6-4. Error Code. ”

【Example】

1. Moves No. 1 and No. 2 axes to respective positions of No. 1=1000 and No. 2=2000 with trapezoidal drive and at speed table No.3.

stx SPS1/1000/2/2000/2/3/0/0/0 CRLF

【Remarks】



Carries out a stop during driving by the stop (STP) command. Refer to the STP command.

(Note) When the Response method is “0:Completed”, Response is not returned if stopped by the STP command.

STP	<i>Stop</i>
------------	-------------

【Function】 Stops the motor driving. You can designate stopping only designated axis or stopping all axes.

【Format】
stx **STP**a/b CRLF Stop designated axis Parameter =2
stx **STP**0/b CRLF Stop all axes

 Space between characters cannot be used. Each parameter cannot be omitted.

Command parameters

	Function	Setting	Remarks
a	Axis No.	0: All axes stop 1 to 2:Axis No.	
b	Selecting stop mode	0: Decelerate and stop 1: Emergency stop	

【Response】 Returns set value.

Status	Response data
Normal	C Tab STP <Axis No.> CRLF
Abnormal	E Tab STP <Axis No.> Tab <Error No.> CRLF

For <Error No.>, refer to the item of "6-4. Error Code."

 Response is transmitted when the axis completely stops.

S T R	<i>Status Read</i>
--------------	--------------------

【Function】 Checks status of the controller.
 Checking driving operations
 Status of limit and sensor
 Error information

【Format】 stx STRa/b CRLF Parameter = 2

Space between characters cannot be used. Each parameter cannot be omitted.

Command parameters

	Function	Setting	Remarks
a	Mode	1	Fixed to 1 (For standard specification)
b	Axis No.	1 to 2	

Designation of mode a is used for special specifications. Normally setting is fixed to 1.

【Response】 Returns status of controller. Returns immediately after receiving the command.

Status	Response data
Normal	C Tab STR <u>A</u> Tab <u>B</u> Tab ... Tab <u>I</u> CRLF
Abnormal	E Tab STR<Axis No.> Tab <Error No.> CRLF

For <Error No.>, refer to the item of "6-4. Error Code."

【Response data】

	Item	Status	Remarks
A	Axis No.	1 to 2	
B	Mode	1	1 Fixed(For standard specification)
C	Driving operations	0: In suspended 1: Operating alone 2: Operating as slave of link 3: Operating with multi-axes drive	
D	NORG signal	0:OFF 1:ON	
E	ORG signal	0:OFF 1:ON	
F	CW limit signal	0:OFF 1:ON	
G	CCW limit signal	0:OFF 1:ON	
H	Swing drive count number	Returns count number	In oscillation drive During normal time, the count number is 0.
I	Error	Returns error No.	If the error No. has read once, then it is cleared to 0.

W R E	<i>Encoder Write</i>
--------------	----------------------

【Function】 Rewrites the counter value of the encoder. The counter value by the encoder signal continues to increase and decrease from the rewritten value.

【Format】 stx WREa/b CRLF Parameter = 2

Space between characters cannot be used. Each parameter cannot be omitted.

Command parameters

	Function	Setting	Remarks
a	Axis No.	1 to 2	
b	Set value	-68,108,813 to 68,108,813	Pulse

【Response】 Returns status.

Status	Response data			
Normal	C	Tab	WRE<Axis No.>	CRLF
Abnormal	E	Tab	WRE<Axis No.>	Tab <Error No.> CRLF

For <Error No.>, refer to the item of "6-4. Error Code."

WRO	<i>Offset Write</i>
------------	---------------------

【Function】 Rewrites the offset value.

【Format】 **stx** **WRO****a**/**b** **CRLF** Parameter = 2

Space between characters cannot be used. Each parameter cannot be omitted.

Command parameters

	Function	Setting	Remarks
a	Axis No.	1 to 2	
b	Offset value	-68,108,813 to 68,108,813	Pulse

【Response】 Returns status.

Status	Response data
Normal	C Tab WRO <Axis No.> CRLF
Abnormal	E Tab WRO <Axis No.> Tab <Error No.> CRLF

For <Error No.>, refer to the item of “6-4. Error Code.”

Writes offset 100 to the present coordinate.

Command: **stx** **RDP2**/**1** **CRLF** **C** **Tab** **RDP2** **Tab** **0** **CRLF**

Command: **stx** **WRO2**/**100** **CRLF** **C** **Tab** **WRO2** **CRLF**

Command: **stx** **RDP2**/**1** **CRLF** **C** **Tab** **RDP2** **Tab** **100** **CRLF**

【Remarks】

The offset is also reflected on the read values converted.
 Issue the ASI and ESI commands in advance.

WRP	<i>Position Write</i>
------------	-----------------------

【Function】 Rewrites the value of the present position.

【Format】 stx WRPa/b CRLF Parameter =2

 Space between characters cannot be used. Each parameter cannot be omitted.

Command parameters

	Function	Setting	Remarks
a	Axis No.	1 to 2	
b	Set value	-68,108,813 to 68,108,813	Pulse

【Response】 Returns status.

Status	Response data			
Normal	C	Tab	WRP<Axis No.>	CRLF
Abnormal	E	Tab	WRP<Axis No.>	Tab <Error No.> CRLF

For <Error No.>, refer to the item of "6-4. Error Code."

W T B	<i>Speed Table Setting Information Write</i>
--------------	--

【Function】 Rewrites the set value of the speed table.

【Format】 **stx** **WTBa/b/c/d/e/f** **CRLF** Parameter = 6

Space between characters cannot be used. Each parameter cannot be omitted.

Command parameters

	Function	Setting	Remarks
a	Axis No.	1 to 2	
b	Speed table No.	1 to 11	1 ~ 9: For drive system 10, 11: Joystick operation speed
c	Start speed	1 to 4,095,500	pps
d	Top speed	1 to 4,095,500	pps Top speed >Start speed
e	Accelerating time	1 to 1,000,000	× 10ms
f	Decelerating time	1 to 1,000,000	× 10ms

Speed table No.1-9 are used for drive commands in remote control, origin return drive, absolute position movement and relative position movement in manual operations.

Speed table No. 10 and 11 are for joystick operation speed in manual operations. No. 10 is the setting in high speed operations, and No. 11 is the setting in low speed operations.

【Response】 Returns status.

Status	Response data
Normal	C Tab WTB <Axis No.> Tab <Speed table No.> CRLF
Abnormal	E Tab WTB <Axis No.> Tab <Error No.> CRLF

For <Error No.>, refer to the item of “6-4. Error Code.”

【Reference】

The RTB Command

【Remarks】

The set content is stored in the backup memory.

T A S	<i>Teaching Function Axis Information Set</i>
--------------	---

【Function】 Sets teaching of the n axes. (Links axis No. with the coordinate memory.)

【Format】 1 axis **stx** **TASa** **CRLF** Parameter = 1
 【Format】 2 axes **stx** **TASa/b** **CRLF** Parameter = 2

 Space between characters cannot be used. Each parameter cannot be omitted.

Command parameters

	Function	Setting	Remarks
a	Designating axis of coordinate memory 1	1 to 2	
b	Designating axis of coordinate memory 2	1 to 2	

【Response】 Returns status of controller.

Status	Response data
Normal	C Tab WTB<The number of axes> CRLF
Abnormal	E Tab WTB<The number of axes> Tab <Error No.> CRLF

<The number of axes> 1 axis = 1, 2 axes = 2, For <Error No.>, refer to the item of “6-4. Error Code.”

【Example】

- Sets teaching of 1 axis. **stx** **TAS1** **CRLF**
 Position data of axis No. 1 is registered into the coordinate memory 1.

【Example】

- Sets teaching of 2 axes. **stx** **TAS1/2** **CRLF**
 Position data of axis No. 1 is registered into the coordinate memory 1.
 Position data of axis No. 2 is registered into the coordinate memory 2.

【Remarks】



Relation between the axis No. and coordinate memory set by this command is stored in the backup memory.



When teaching of 1 axis is performed, writing in the coordinate memory 2 (the WRT command), even if it is carried out, is invalid.

TMS	<i>Teaching Function Position Information Set</i>
------------	---

【Function】 Writes the coordinate value of the axis No. linked by the TAS command in the designated memory address.

【Format】 `stx TMSa CRLF` Parameter = 1

Space between characters cannot be used. Each parameter cannot be omitted.

Command parameters

	Function	Setting	Remarks
a	Coordinate memory address	0 to 10,000	

【Response】 Returns status of controller. Returns immediately after receiving the command.

Status	Response data
Normal	<code>C Tab TMS<The number of axes> CRLF <Memory address> CRLF</code>
Abnormal	<code>E Tab TMS<The number of axes> Tab <Error No.> CRLF</code>

<The number of axes> 1 axis = 1, 2 axes = 2, For <Error No.>, refer to the item of “6-4. Error Code.”

【Example】

Performs teaching to write the coordinate values of 3 axes.

```

stx TAS1/2/4 CRLF
stx APS1/2/0/0/100/0/0/1 CRLF
stx APS2/2/0/0/100/0/0/1 CRLF
stx TMS0 CRLF

stx APS1/2/0/0/110/0/0/1 CRLF
stx APS2/2/0/0/120/0/0/1 CRLF
stx TMS1 CRLF

stx APS1/2/0/0/115/0/0/1 CRLF
stx APS2/2/0/0/125/0/0/1 CRLF
stx TMS2 CRLF

stx APS1/2/0/0/10/0/0/1 CRLF
stx APS2/2/0/0/20/0/0/1 CRLF
stx TMS3 CRLF
    
```

Address	Axis No. 1		Axis No. 2	
	Coordinate value	Speed	Coordinate value	Speed
0	100	0	100	0
1	110	0	120	0
2	115	0	125	0
3	10	0	20	0

【Related】

The RDT Command read teaching table

The WRT Command write teaching table

【Remarks】

For the speed tables, the speed table 0 is stored as a default when the TMS command is issued. When attempting to change the speed table, use the WRT command to change.

TPS	<i>Teaching Function Teaching Drive</i>
------------	---

【Function】 Drives axis according to the value of the designated coordinate memory address.

【Format】 `stx` `TPS``a`/`b` `CRLF` Parameter = 2

Space between characters cannot be used. Each parameter cannot be omitted.

Command parameters

	Function	Setting	Remarks
a	Coordinate memory address	0 to 10,000	Varies according to model
b	Response method	0:Copmpleted 1:Quick	

【Response】 Returns status of controller.

Status	Response data
Normal	<code>C</code> <code>Tab</code> <code>TPS</code> <The number of axes> <code>CRLF</code>
Abnormal	<code>W</code> <code>Tab</code> <code>TPS</code> <The number of axes> <code>CRLF</code> <Warning No.> <code>CRLF</code>
	<code>E</code> <code>Tab</code> <code>TPS</code> <The number of axes > <code>Tab</code> <Error No.> <code>CRLF</code>

<The number of axes> 1 axis = 1, 2 axes = 2, For the <Error No.> and <Warning No.>, refer to the " 6-4. Error Code. "

【Example】

When the coordinate data is set as in the table below.

<code>stx</code> <code>TPS</code> 0/0 <code>CRLF</code>	→	<code>C</code> <code>Tab</code> <code>TPS</code> 3 <code>CRLF</code>	Moves to the coordinate of memory address 0
<code>stx</code> <code>TPS</code> 1/0 <code>CRLF</code>	→	<code>C</code> <code>Tab</code> <code>TPS</code> 3 <code>CRLF</code>	Moves to the coordinate of memory address 1
<code>stx</code> <code>TPS</code> 2/0 <code>CRLF</code>	→	<code>C</code> <code>Tab</code> <code>TPS</code> 3 <code>CRLF</code>	Moves to the coordinate of memory address 2
<code>stx</code> <code>TPS</code> 3/0 <code>CRLF</code>	→	<code>C</code> <code>Tab</code> <code>TPS</code> 3 <code>CRLF</code>	Moves to the coordinate of memory address 3
<code>stx</code> <code>TPS</code> 4/0 <code>CRLF</code>	→	<code>W</code> <code>Tab</code> <code>TPS</code> 3 <code>Tab</code> 100 <code>CRLF</code>	Coordinate data is not set

Address	Axis No. 1		Axis No. 2	
	Coordinate value	Speed	Coordinate value	Speed
0	100	0	100	0
1	110	0	120	0
2	115	0	125	0
3	10	0	20	0
4	----	----	----	----
----	----	----	----	----
9999	----	----	----	----

RDT	<i>Teaching Function Position Data Read</i>
------------	---

【Functions】 Reads out teaching data. This can be used as an editing function.

【Format】 **stx** RDT**a**/**b** **CRLF** Parameter = 2

Space between characters cannot be used. Each parameter cannot be omitted.

Command parameters

	Function	Setting	Remarks
a	Axis No.	1 to 2	
b	Coordinate memory address	0 to 10,000	

【Response】 Returns the position information and speed table No.

Status	Response data
Normal	C Tab RDT<Axis No.> Tab <Position information> Tab <Speed Table No.> CRLF
Abnormal	W Tab RDT<Axis No.> Tab <Warning No.> CRLF
	E Tab RDT<Axis No.> Tab <Error No.> CRLF

For <Error No.>, refer to the item of “6-4. Error Code.”

【Example】 Reads out the coordinate memory address 100 of axis No. 1.

stx RDT1/100**CRLF** \Rightarrow **C** **Tab** RDT1 **Tab** 1234 **Tab** 0 **CRLF**

WRT	<i>Teaching Function Position Data Write</i>
------------	--

【Functions】 Rewrites the teaching data. This can be used as editing function.

【Format】 **stx** WRT**a**/**b**/**c**/**d** **CRLF** Parameter = 4

Space between characters cannot be used. Each parameter cannot be omitted.

Command parameters

	Function	Setting	Remarks
a	Axis No.	1 to 2	
b	Coordinate memory address	0 to 10000	
c	Set value	-68,108,813 to 68,108,813	Pulse
d	Speed table selection	0 to 9	

【Response】 Returns status of controller.

Status	Response data
Normal	C Tab WRT<Axis No.> CRLF
Abnormal	E Tab WRT<Axis No.> Tab <Error No.> CRLF

For <Error No.>, refer to the item of “6-4. Error Code.”

【Example】 Writes the position information 1245 and speed table selection 7 in the coordinate memory 100 of axis No. 1.

stx WRT1/100/1245/7 **CRLF** \Rightarrow **C** **Tab** WRT1 **CRLF**

 Easy control commands are a group of commands to drive with minimum parameters by using parameters set via manual operation. Therefore, please notice that the movement changes when the internal parameters are changed via manual operation.

PMS	<i>Easy Control Speed Change</i>
------------	----------------------------------

【Functions】 Designates a speed table when executing easy control commands.

【Format】 `stx PMSa/b CRLF` Parameter = 2

 Space between characters cannot be used. Each parameter cannot be omitted.
Command parameters

	Function	Setting	Remarks
a	Axis No.	1 to 2	
b	Speed table No.	0 to 9	

【Response】 The response method is fixed to Quick method.

Status	Response data
Normal	<code>C Tab PMS<Axis No.> CRLF</code>
Abnormal	<code>E Tab PMS<Axis No.> Tab <Error No.> CRLF</code>

For <Error No.>, refer to the item of "6-4. Error Code."

【Example】 Designates the speed table to 5 when executing easy control commands.

`stx PMS1/5 CRLF` \Rightarrow `C Tab PMS1 CRLF`

PMP	<i>Easy Control Relative Position Drive</i>
------------	---

【Functions】 Performs relative position movement.

【Format】 **stx** **PMP**a/b **CRLF** Parameter = 2

 Space between characters cannot be used. Each parameter cannot be omitted.
Command parameters

	Function	Setting	Remarks
a	Axis No.	1 to 2	
b	Movement amount	-16,777,215 to 16,777,215	Pulse

【Response】 The response method is fixed to Quick method. Use the STR command to check the end of moving.

Status	Response data
Normal	C Tab PMP <Axis No.> CRLF
Abnormal	E Tab PMP <Axis No.> Tab <Error No.> CRLF

For <Error No.>, refer to the item of “6-4. Error Code.”

【Example】 Performs relative position movement of the axis No. 1 by 1000 pulses.

stx **PMP**1/5**CRLF**  **C** **Tab** **PMP**1**CRLF**

【Remarks】

 Drives with accelerating and decelerating mode (SYS No.22), backlash correction method (SYS No.8), and encoder correction method (SYS No.29) of the each values system construction (SYS mode).

PMA	<i>Easy Control Absolute Position Drive</i>
------------	---

【Functions】 Performs absolute position movement.

【Format】 **stx** PMA**a**/**b** **CRLF** Parameter = 2

Space between characters cannot be used. Each parameter cannot be omitted.

Command parameters

	Function	Setting	Remarks
a	Axis No.	1 to 2	
b	Moving target position	-68,108,813 to 68,108,813	Regarding to setting the target position, the amounts of the movement between the target position and the current position should be set up the value of the range from -16,777,215 to 16,777,215.

【Response】 The response method is fixed to Quick method. Use the STR command to check the end of moving.

Status	Response data
Normal	C Tab PMA<Axis No.> CRLF
Abnormal	E Tab PMA<Axis No.> Tab <Error No.> CRLF

For <Error No.>, refer to the item of "6-4. Error Code."

【Example】 Performs absolute position movement of the axis No. 1 by 1000 pulses.

stx PMA1/1000**CRLF** \longrightarrow **C** **Tab** PMA1**CRLF**

【Remarks】

Drives with accelerating and decelerating mode (SYS No.22), backlash correction method (SYS No.8), and encoder correction method (SYS No.29) of the each values system construction (SYS mode).

PMH	<i>Easy Control Origin Search</i>
------------	-----------------------------------

【Functions】 Performs origin return movement.

【Format】 **stx** **PMH****a** **CRLF** Parameter = 1

 Space between characters cannot be used. Each parameter cannot be omitted.
Command parameters

	Function	Setting	Remarks
a	Axis No.	1 to 2	

【Response】 The response method is fixed to Quick method. Use the STR command to check the end of moving.

Status	Response data
Normal	C Tab PMH <Axis No.> CRLF
Abnormal	E Tab PMH <Axis No.> Tab <Error No.> CRLF

For <Error No.>, refer to the item of “6-4. Error Code.”

【Example】 Performs origin search for the axis No. 1.

stx **PMH****1** **CRLF** \longrightarrow **C** **Tab** **PMH****1** **CRLF**

【Remarks】

 Drives with Origin return method (SYS No.9) of the system construction (SYS mode).

R C P	<i>Constant Pulse Read</i>
--------------	----------------------------

【Functions】 Reads out the set constant speed pulses at deceleration.

【Format】 **stx** RCPa **CRLF** Parameter = 1

Space between characters cannot be used. Each parameter cannot be omitted.

Command parameters

	Function	Setting	Remarks
a	Axis No.	1 to 2	

【Response】 Returns status information. Return timing depends on the response method.

Status	Response data
Normal	C Tab RCP <Axis No.> CRLF
Abnormal	E Tab RCP <Axis No.> Tab <Error No.> CRLF

For the <Error No.> and <Warning No.>, refer to the “ 6-4. Error Code. ”

W C P	<i>Constant Pulse Write</i>
--------------	-----------------------------

【Functions】 Sets constant speed pulses at deceleration.

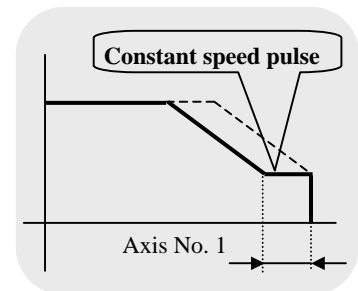

【Format】 **stx** WCPa/b **CRLF** Parameter = 2

Space between characters cannot be used. Each parameter cannot be omitted.

Command parameters

	Function	Setting	Remarks
a	Axis No.	1 to 2	
b	Constant speed pulse	0 to 20,000	

【Response】 Returns status information. Return timing depends on the response method.

Status	Response data
Normal	C Tab WCP<Axis No.> CRLF
Abnormal	E Tab WCP<Axis No.> Tab <Error No.> CRLF

For the <Error No.> and <Warning No.>, refer to the “ 6-4. Error Code. ”

【Remarks】

The set content is stored in the backup memory.

6-4. Error Code

6-4-1. Error Code

If an error is confirmed when transmitting a command, the controller returns the response with the error code.

In addition, after a drive error occurs, you can check the error code with the STR command (status read).

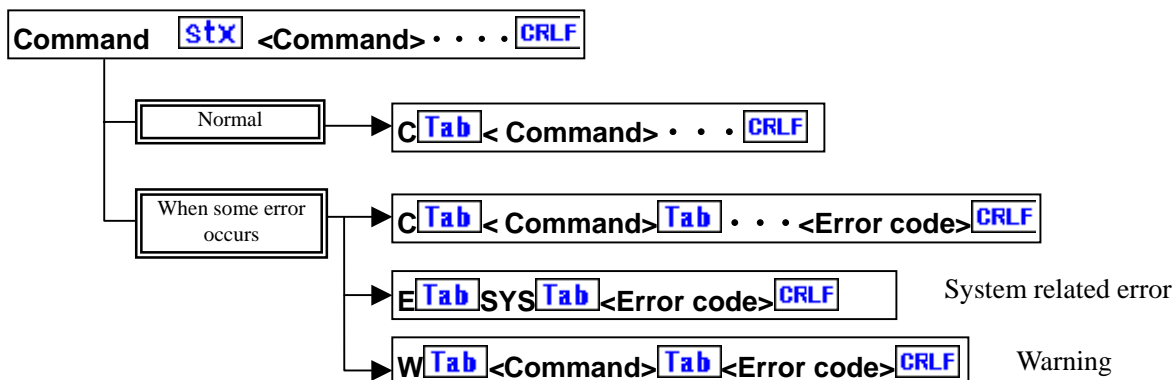

When no error occurs, the head character is C. When some error occurs, the error code with E or W is returned.

6-4-2. List of Error Codes

System Related Error (independent of the command type)

Error code	Description	Remarks
1	No STX on head of the command.	
2	Total number of commands is short.	
3	Absence of CR+LF	
4	Character other than specified characters and figures is included.	
5	No applicable command.	
10	Now operating in manual mode.	

Parameter Error

Error code	Description	Remarks
100	Total number of parameters is incorrect.	
1n ₁ n ₂	Numerical value of n ₁ n ₂ th parameter is out of range.	n ₁ n ₂ = 01 to 14
120	Value is designated so that movable value at one time is exceeded.	

Command Issue Sequence Error

Error code	Description	Remarks
200	Reset command is not issued.	
201	The MSI and ASI commands are not issued.	
202	Link command is not issued.	
205	The ORG command is not issued. (Origin is not detected)	
206	The APS/RPS? command corresponding to the first parameter of the MPS command is not issued.	
207	The APS/RPS? command corresponding to the second parameter of the MPS command is not issued.	
208	The APS/RPS? command corresponding to the third parameter of the MPS command is not issued.	
209	APS/RPS? command corresponding to the fourth parameter of the MPS command is not issued.	
210	The ESI command is not issued.	

(To next page)

(From last page)

Drive Related Error

Error code	Description	Remarks
300	PMG is in use.	Inside IC (Integrated circuit) related error
301	Speed setting is 0 in rectangular drive.	
302	Operating the axis during driving.	
303	Tried to rewrite the present value of the axis during driving.	
304	Stopped by CW limiter during driving.	
305	Stopped by CCW limiter during driving.	
306	Any axis on MPS driving stopped by limiter.	
307	Both of CW and CCW limiters are activated.	
308	Tried to move the axis for which excitation is OFF.	
309	Out of the control range in feedback control.	

Link Related Error

Error code	Description	Remarks
400	Hardware which does not allow for LNK driving.	
401	Operating axis during LNK driving.	
402	Link counter is now in use.	
403	Tried to rewrite present value of axis during LNK driving.	
404	Designated to stop axis which is driving by slave axis.	
405	Axis designation of LNK slave 1 is incorrect.	
406	Axis designation of LNK slave 2 is incorrect.	

Multi-Axes Setting Error

Error code	Description	Remarks
501	First parameter and second parameter are the same.	
502	First parameter and third parameter are the same.	
503	First parameter and fourth parameter are the same	
504	Second parameter and third parameter are the same.	
505	Second parameter and fourth parameter are the same.	
506	Third parameter and fourth parameter are the same.	

ASI, WTB, RTB Command Calculation Error

Error code	Description	Remarks
600	Accelerating pulse number is large, or accelerating time is long.	
601	Accelerating pulse number is small, or accelerating time is short.	
602	Decelerating pulse number is large, or decelerating time is long.	
603	Decelerating pulse number is small, or decelerating time is short.	
604	Preparation failure of speed table with the WTB command.	

Controller Error

Error code	Description	Remarks
700	The command and the parameter uncorresponds to were issued.	

Scanning Error

Error code	Description	Remarks
1102	The value specified by the SCN command for the movement amount did not come up to twice measuring STEP.	

Teaching Error

Error code	Description	Remarks
1200	In teaching function, positional coordinates aren't written in the memory of specified axis No.	

Warning Message

Error code	Description	Remarks
1	The target position and present position are the same.	
2	In one move setting, waiting time is designated with OSC command.	
100	Designated address to which a coordinate is not registered by the TPS command.	

MEMO

6. Internal Motor Driver

6-1. Driver Specifications

SC-021	
Model	DS507F-2 or DS503F-2
Pwer supply	DC24V 1.4A Max. DC5V 0.02A Max.
Output current	Rated current : 0.75A/Phase(DS507F-2) , 0.35A/Phase(DS503F-2)
Input signal	C-MOS input
Maximum response frequency	800kpps Max
Output signal	C-MOS output
Setting of micro-step interpolation	For micro-step driving of one type only, set the number interpolation using the digital SW DSW4 and DSW5. 16 steps(refer to 119 pages)
Operating temperature & humidity	0-40 85%RH Max without any dew any condensed.
Storage temperature & humidity	0-80 85% RH Max without any dew any condensed.
Mass	Approximately 40g

The above-mentioned is a specification in the driver unit only.

6-2. Arrangement of Driver

Built-in stepping motor drivers are posted under the main board.

《SC-021》

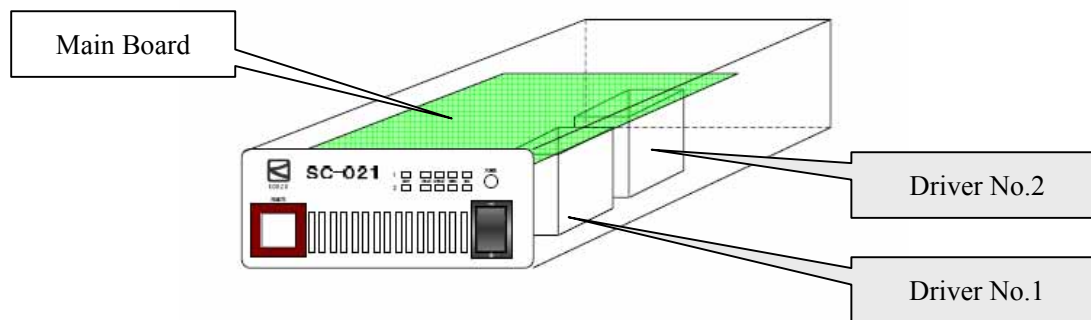

6-3. Open and Close of Enclosure, Adjustment of Driver

Adjustments of the driver in the controller are required in order to perform setting of the division number for the micro step or to adjust output current.
 Method to open and close the controller enclosure is as follows.

Opening and Closing Enclosure

 Do not plug into the controller for your safety when you will open the housing.

Remove the 8 screws on the top cover and bottom cover.



Pull up the top cover and bottom cover.



The adjustment part for DSW4 and DSW5 on the main board.(Resolution SW)
 The adjustment part for Driver under the main board is seen from the rear side, and make adjustments by using tweezers and a clock driver.(RUN current, STOP current)

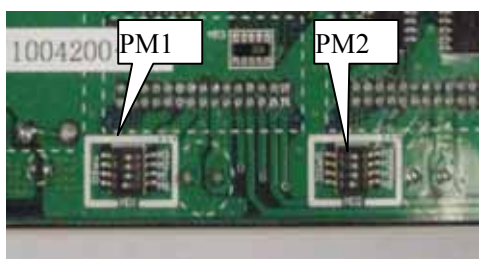

Carry out carefully so that no breakage or abnormality occurs.



A change in parts other than the driver adjustment part such as the switch is not allowed.



Please be advised that some products in SC Series differ in the method of opening the enclosure depending on the specifications.

Setting of Micro Step division number.

Set the micro step division number with the digital switch DSW4, DSW5.

The setting of the switch and the division number is as in following table.

(Setting table for division number)

The driver is set to the setting 2 resolution when shipped from the factory.

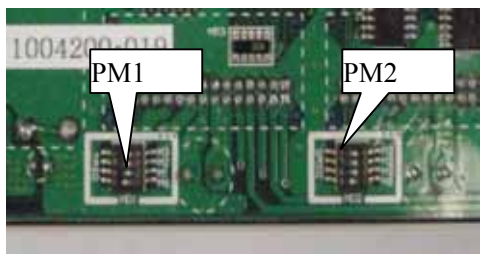

Setting table for division number

		<u>Resolution</u>															
		1	2	2.5	4	5	8	10	20	25	40	50	80	100	125	200	250
SW Setting	M0	OFF	ON	OFF	ON	OFF	ON	OFF	ON	OFF	ON	OFF	ON	OFF	ON	OFF	ON
	M1	OFF	OFF	ON	ON	OFF	OFF	ON	ON	OFF	OFF	ON	ON	OFF	OFF	ON	ON
	M2	OFF	OFF	OFF	OFF	ON	ON	ON	ON	OFF	OFF	OFF	OFF	ON	ON	ON	ON
	M3	OFF	OFF	OFF	OFF	OFF	OFF	OFF	OFF	OFF	ON	ON	ON	ON	ON	ON	ON



Carry out carefully so that no breakage or abnormality occurs.



A change in parts other than the driver adjustment part such as the switch is not allowed.

Setting of Drive Current and Stop Current.

Set the current when the motor is running and stop with the current trimmer switch indicated as RUN and Stop. (Don't use ECO switch)

The setting and the current value is as in the following graph.



■ Ranges of current setting

< Microstep >

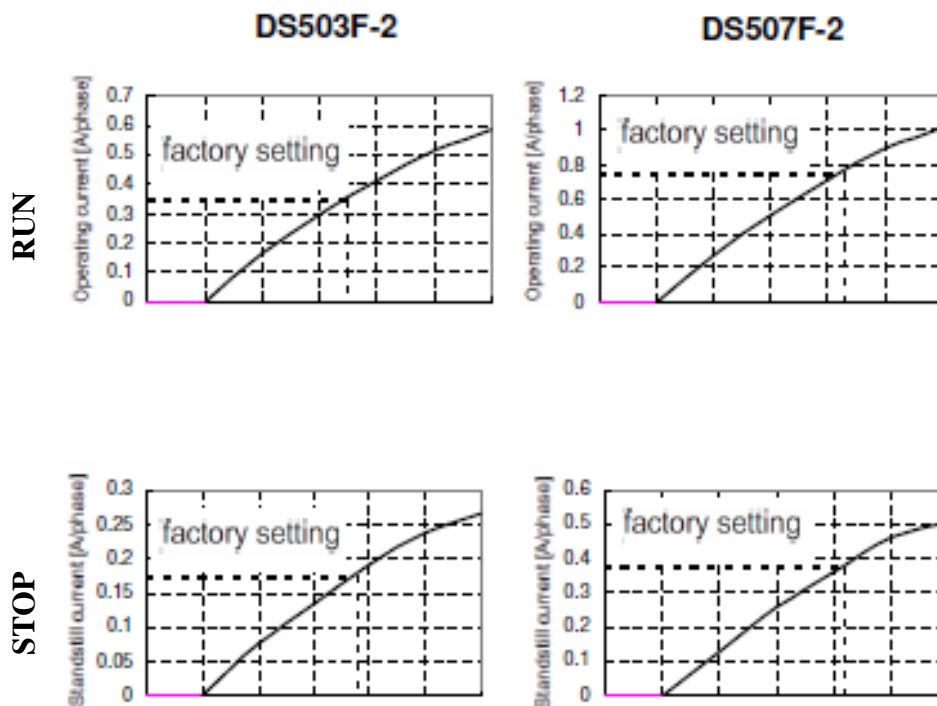

6-4. Change in Encoder Input System

In SC-021, the encoder input method can be selected from differential input/open collector input. When the encoder input method is changed, it is necessary to replace the jumper pin. The setting when shipping it is a differential input setting.

《encoder signal input》

1. Open Enclosure (refer to P.117), please remove top cover after removing 4 hexagon socket screw at the body side. And set the jumper-pin on the main board

 Do not plug into the controller for your safety when you will open the housing.



2. The jumper on the above-mentioned substrate like the photograph below "Differential input" of the encoder input or "Open collector input" is selected with pin JP1 (four places). (The setting when shipping it is a differential input setting.) Move the jumper pin to the open collector side when you use the encoder of the open collector input type.

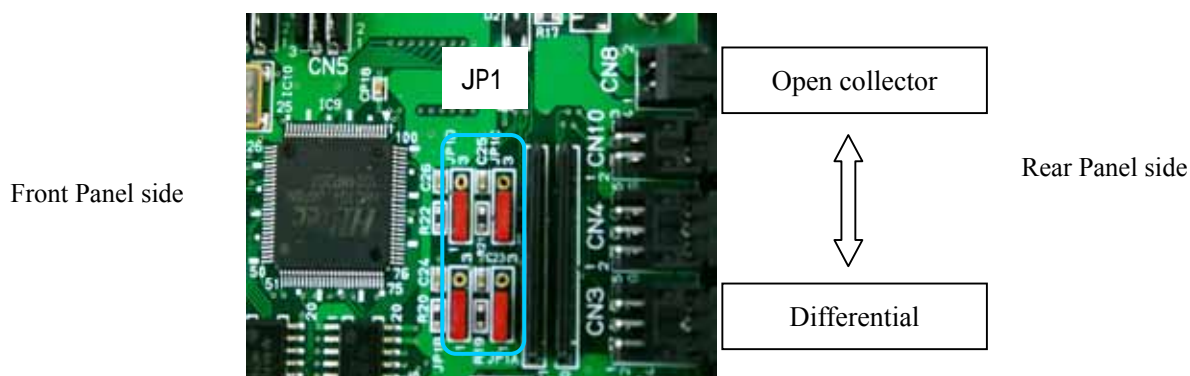

The setting of the photograph is Differential.

7. Maintenance and After-Service

7-1. Before you judge as failure

Power is not turned on

Is the power cord pulled out or loosened?

Plug the power cord into the main body securely.

Is the fuse on the rear panel inserted or burnt?

Insert or replace with a new fuse.

(If the fuse frequently burns out, this may be caused by an internal failure.)

Is power conducted to the outlet?

Plug the power cord of another electric appliance into the outlet, and check if the appliance operates.

Check if power is applied with a voltmeter such as a tester.

Is the power cord broken at some point ?

Check conductivity between both ends of the cord if you have a tester.

The display plate and switches on the front panel do not light up while the heat release fan is rotating.

After turning off the power, turn on the power again. If the same phenomenon occurs, this is considered to be an internal failure.

Display on the front panel is incorrect.

Characters displayed are incorrect. That is, not displayed correctly.

Try to adjust the contrast of Front Panel.(Refer to “4-1. Front Panel”)

After turning off the power, turn on the power again. If the same phenomenon occurs, this is considered to be an internal failure.

The device does not operate even when the joystick is tilted

Is “Non” displayed on the right upper portion of the liquid crystal screen?

This is in the prohibitive mode for joystick operations. Press the switch on the right upper portion of the display, and change the mode.

Is there a rotating sound or abnormal sound?

This is considered to be an out-of-adjustment of the motor, therefore, change the speed, or adjust the output current of the driver.

(When there is a rotating sound), is the motor rotating ?

If the device has been used for a long period of time, the coupling of the motor shaft may be loosened in some rare cases.

(When there is no rotating sound), do the limit indications light up?

The device stopped by the limit switch. Move in the reverse direction and move through the limit zone.

(When there is no rotating sound), is the stage connecting cable pulled out, or loosened ?

Securely plug the stage connector into the main body connector.

(In case of multi-axes specification), do all axes of the move ?

If some axes move, but others do not, exchange the connectors of respective axes (motor), and determine whether trouble is caused on the main body side or motor side.

Origin return operations cannot be performed

Do the motors completely operate ?

Check the other items such as “The device does not operate even when the joystick is tilted”.

(The axis stops at position which is not origin), is the origin sensor correctly installed ?

Adjust the origin sensor.

In such a case where the moving range is small, the limit sensor range may overlap with the origin sensor range. In this case, the device does not operate properly. Make an adjustment so that the origin sensor range is out of the limit range.

When using the origin proximity sensor and origin sensor, take the positional relationship into account. If the origin is out of the origin proximity sensor range, the axis cannot return to the origin properly. Make an adjustment of the origin position.

(The axis stops at a position which is not the origin), is logic for origin sensor properly set ?

Switch the input logic for the sensor (Normal open, Normal close).

Positional deviation

Is the setting such that the moving step value is incorrect?

Check each setting according to the Operation Manual.

Is the motor properly operating ? Does an abnormal sound occur ?

An out-of adjustment may be considered, therefore, change the speed, or adjust the output current of the driver.

Is the load exceeding the rated applied ?

Check the load. Also try to lower the speed.

Is the axis in the limit range ?

In a case where the axis is in the limit range, the stop position and counter value are not guaranteed. Use it out of the limit range.

Is there any problem with the motor assembly and driving portions ?

If the device has been used for a long period of time, the coupling of the motor shaft may be loosened.

Remote control (RS-232C, GP-IB) does not operate properly

Is the communications cable pulled out or loosened ?

Plug the connector of the communications cable into the connector of the main body surely.

Have the parameter settings of RS-232C and address settings of GP-IB been properly performed ?

Read the setting method in the Operation Manual for a check.

(After the settings have been changed, turn on the power again.)

Is a proper cable used ?

Check the arrangement of the connector pins on each cable.

During communications, is any error code transmitted ?

Take measures for an error on the host computer.

Is there any error in the control program on the host computer ?

Check the program. Please note that errors such as distinction between upper and lower case letters and setting of the delimiter code frequently occur.

Are commands transmitted and received properly ? Make sure to receive data for commands which have a response (for example, status reading).

Checking by support software. Support software which can be easily operated is also available.

If proper operations can be performed by the support software, it is considered that the user's software is not correctly written.

Are communications forcedly interrupted mid-stream?

Turn on the power again.

7-2. Maintenance of Product

Maintenance of Controller

- In such cases of using in a dusty room, carry out internal cleaning periodically.
- When not using or storing for a long period of time, make sure to disconnect the power cord from the outlet and also to remove the other cables.
- Maintenance and service other than troubleshooting shall be carried out only by us at cost.

Maintenance of Stage

【Lubrication】

【Looseness of screws】

【Looseness of couplings】

7-3. Contact

If you have question about our products, fill in the necessary items below and notify us by FAX or mail.
 Questions by E-mail are also acceptable.

To KOHZU Precision Co., Ltd., Sales Department
 2-6-15, Kurigi, Asao-ku, Kawasaki-shi, Kanagawa 215-8521 Japan

FAX +81-44-981-2181 E-mail: sale@kohzu.co.jp

Product name SC-		Contact date	
		Serial No.	Date / / ()
Customer	Name	TEL	FAX
		Extension	
	Name of company, school or institution	E-mail	
	Department, Affiliation	Address 〒	
Reason for contact Failure How to use Hardware Software			

Please do not hesitate to notify us of your questions and opinions about our company and our products.

7-4. Warranty and After-Service

If the product fails within the warranty period, we will repair free of charge under our stipulations.

Warranty Period	One year from the date of shipment
-----------------	------------------------------------

Request for repair within warranty period

Please contact the sales agent or commercial firm from which you purchased our product, or our Sales Department.

Repair after warranty period has elapsed

Even if the warranty period has elapsed, initially, consult the sales agent or commercial firm from which you purchased the product. Repairs shall be carried out depending on failure at cost.

Maintenance for repairing parts

We will carry out maintenance of most parts for repair within a period specified by us after discontinuing production. Please understand that repair requiring parts for which the warranty period has elapsed may be rejected. Also, this condition may not be satisfied due to inconvenience of the parts supply maker.

8. Specification

8-1. General Specifications

	SC-021
Number of axes controlled	2 axes
Number of axes controlled simultaneously	2 axes
Drive motor	5 phases stepping motor
Driver type	Micro step drive
Power for driver	DC24V DC5V
Power electricity consumption	AC100V、 50/60Hz 80VA (2 axes motion at 0.75A)
Operating environment	Temperature 0°C to 40°C Humidity 0 to 85%
Exterior dimensions (mm)	W107 × H44 × D220
Weight	1180g

8-2. Performance Specifications

	SC-021
Driving Function	2 axes simultaneously/independently, 2 axes linear interpolation, Trapezoidal/asymmetric trapezoidal drive, S-shaped/asymmetric S-shaped drive
Micro Step Division Number	16 stages 1/2/2.5/4/5/8/10/20/25/40/50/80/100/125/200/250
Set Movement amount	1 to 16,777,215 pulse
Driving Frequency	1 to 800 Kpps (according to driver)
Origin Return Method	14 methods
Display Type	Display by pulse, Display by conversion pulse, Display by encoder, Display by conversion encoder
Communications Function	RS-232C
Others	Continuous drive, Swing drive

8-3. Connector

9-3-1. Motor Connecting Connector

The bellow pin arrangement figure is the figure which is shown from the connector side.

Connector model : RP13A-12R-13SC made by HIROSE ELECTRIC Co.,Ltd.

(Conformity connector : RP13A-12PA-13PC made by HIROSE ELECTRIC Co.,Ltd.)

(Conformity contact : RP19-PC-122)

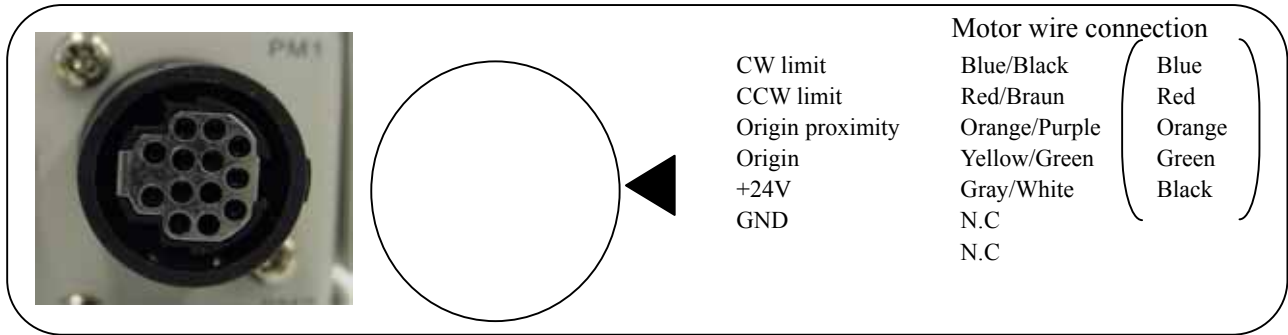

The colors of motor line are those of ten lead motors made in Oriental Motor Co.,Ltd..

The colors of motor line bound with a parenthesis are those of five lead motor made in Oriental Motor Co.,Ltd. or Tamagawa Seiki Co.,Ltd..

9-3-2. Encoder Connecting Connector

Connector model : HR10A-7R-6SC made by HIROSE ELECTRIC Co.,Ltd.

(Conformity connector : HR10A-7P-6PC made by HIROSE ELECTRIC Co.,Ltd.)

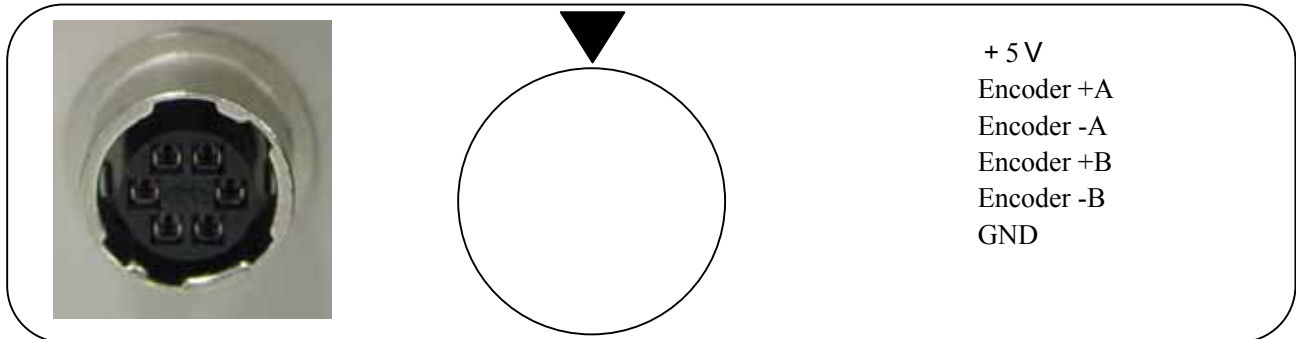

9-3-2. RS-232C Connector



The installation screw is inch type.

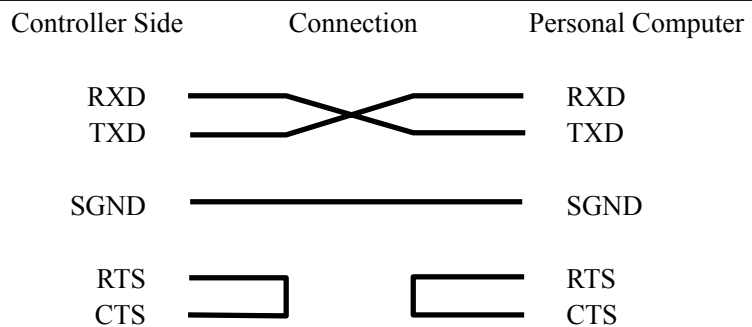

8-4. Exterior Dimensions

SC-021

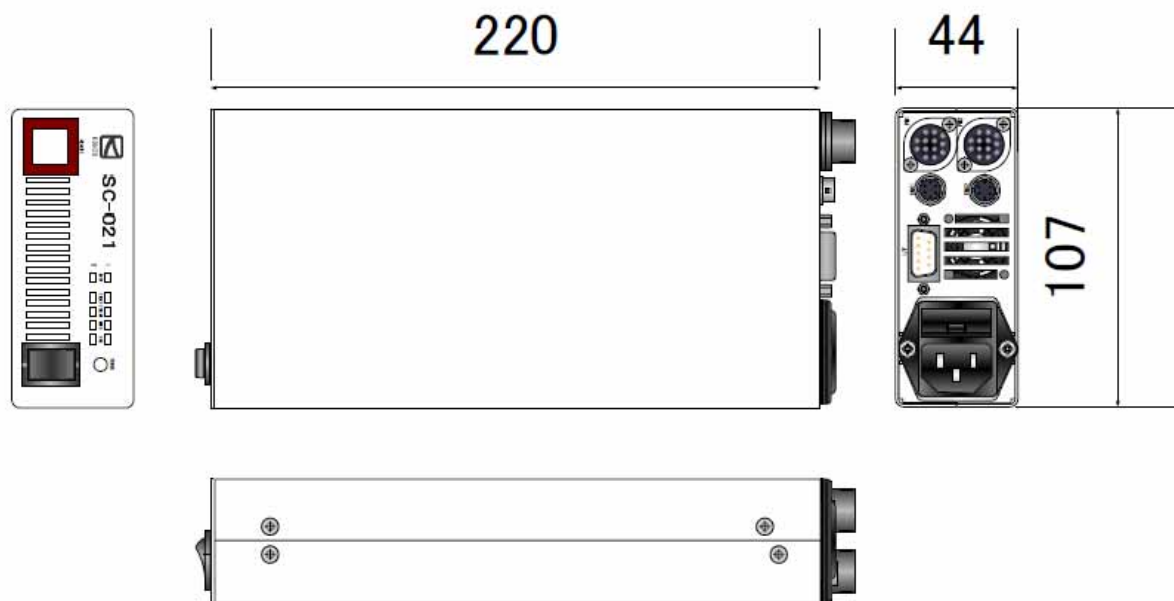

9. Attached CD-R

9-1. Configuration

The description of the attached CD-R is as follows.

Description	Remarks
SC-021 Operation manual	This reference

Descriptions may be subject to change without prior notice.

9-2. Sample Software

- The sample software that SC controller can operate from PC is prepared.
The sample software can be downloaded from our HP.(<http://www.kohzu.co.jp/>)

Appendix

System Setting List

SYS No.	Display	Function	Setting range	Initial value
1	START SPEED(pps)	Start speed of speed table No.0	1 to 4,095,500	500
2	TOP SPEED(pps)	Maximum speed of speed table No.0	1 to 4,095,500	5,000
3	ACC TIME (10ms)	Accelerating time of speed table No.0	1 to 3,275	24
4	DEC TIME (10ms)	Decelerating time of speed table No.0	1 to 3,275	24
5	ORG PRESET DATA	Coordinate value after return to origin	-16,777,215 to +16,777,215	0
6	PM PRESCALE	Motor pulse pre-scalar 0 clear position when using the multi-rotation stage	0 to 16,777,215	0
7	BACKLASH PULSE	Backlash correction Pulse amount	0 to 16,777,215	0
8	BACKLASH TYPE 0-4	Backlash correction 0: Invalid 1 to 4: the selected method	0 to 4	0
9	ORG TYPE 1-17	Selection of origin return method ORG method No.15 is a optional function.	1 to 17	3
10	PLS CAL DIV 1/N	Motor pulse conversion Denominator	1 to 16,777,215	1
11	PLS CAL DIV N/1	Motor pulse conversion Numerator	1 to 16,777,215	1
12	PLS RND OFF 0-9	Motor pulse conversion Designating rounding	0 to 9	2
13	STOP EMG : 0 Fixed	Limit stop method (This function is optional.) 0: Emergency 1: Deceleration	0,1	0
14	OFFSET DATA	Offset	-16,777,215 to +16,777,215	0
15	PM ROTATE CHANGE	Change of rotating direction	0,1	0
16	CWL NON:0 INV:1	CW limiter signal logic	0,1	0
17	CCWL NON:0 INV:1	CCW limiter signal logic	0,1	0
18	NORG NON:0 INV:1	NORG sensor signal logic	0,1	0
19	ORG NON:0 INV:1	ORG sensor signal logic	0,1	0
20	LMT SWAP N:0 Y:1	exchange CW limiter signal and CCW limiter signal	0,1	0
21	COFF ON:0 OFF:1	Motor excitation 0: Excitation ON 1: Excitation OFF	0,1	0
22	ACC CURVE 1-5	Accelerating and decelerating mode 1:Rectangular drive 2:Trapezoidal drive 3:Asymmetric trapezoidal drive 4:S-shaped drive 5:Asymmetric S-shaped drive	1 to 5	2
23	CONSTANT PULSE	low-speed movement pulses until stopping after it decelerates	1 to 16,777,215	5
24	ENC CAL DIV 1/N	Encoder pulse conversion Denominator	1 to 16,777,215	1
25	ENC CAL DIV N/1	Encoder pulse conversion Numerator	1 to 16,777,215	1
26	ENC MULTIPLI 1-4	Encoder pulse multiplication settings 1:1 multiplication 2:2 multiplication 4:4 multiplication	1,2,4	1
27	ENC PRESCALE	Encoder pulse 0 clear position when using the multi-rotation stage	0 to 16,777,215	0
28	ENC RND OFF 0-9	Encoder pulse conversion Designating rounding	0 to 9	2

SYS No.	Display	Function	Setting range	Initial value
29	FEEDBACK TYPE 0-2	Encoder correction settings 0: Not correct 1: Correct (only in positioning) 2: Correct (constant)	0 to 2	0
30	PERMIT RANGE PULS	Encoder correction Permissible range (Pulse)	1	1
31	RETRY COUNT	Encoder correction Retry number (times)	1 to 10,000	100
32	WAIT TIME (1ms)	Encoder correction Wait time (ms)	1 to 10,000	100
33	ENC ROTATE CHANGE	Encoder addition direction	0,1	0
34	PM&ENC SYNC WRITE	Encoder coordinate synchronization	0,1	0
35	SPD TABLE 1-300	Speed table multiple setting	1 to 300	1
36	SYS Refresh!! Pass:0 Exec:1	Initialization of system 0: Pass 1: Execute initializing	0,1	0
37	DSP Line No1 Axis_No Select	RC-010s LCD panel Axis No.(First Line) displayed in second line	1, 2	1
38	DSP Line No1	Selection of conversion display (First Line) 0: Pulse display 1: Encoder display 2: Conversion Pulse display 3: Conversion Encoder display	0 to 3	0
39	DSP Line No2 Axis_No Select	RC-010s LCD panel Axis No.(Second Line) displayed in second line	1,2	2
40	DSP Line No2	Selection of conversion display (Second Line) 0: Pulse display 1: Encoder display 2: Conversion Pulse display 3: Conversion Encoder display	0 to 3	0
41	Manual Hi Speed (speed table)	Manual Hi Speed change. (SCAN MODE)	0 to 9	7
42	Manual Low Speed (speed table)	Manual Low Speed change. (SCAN MODE)	0 to 9	1
43	SCAN Pulse Value	Setting of amount of movement pulse by operation once. (SCAN MODE)	0 to 999,999	1

List of Commands

The commands that are usable in SC-021 are as in the table below.

For details, refer to the pages for respective commands.

Type	Descriptio	Command Function	Applicable model SC-		Page
			021	410	
Settings	RST	System Reset			78
	MPC	Motor-related Polarity Change			66
	ASI	Motor-related Initial Setting (set acceleration and deceleration by time)			56
	MSI	Motor-related Initial Setting (set acceleration and deceleration with STEP)			56
	ESI	Encoder-related Initial Settings			62
	DSP	Display Switching			61
	RSI	Change Rectangular Drive Speed			77
Drive	ORG	Origin Return Drive			68
	APS	Absolute Position Drive			55
	RPS	Relative Position Drive			76
	SPS	Linear Interpolate Drive			81
	MPS	Multi-axis Position Drive	2 axes		67
	OSC	Oscillation Drive			69
	FRP	Free Rotation Drive			63
	STP	Stop			83
	COF	ON/OFF for Excitation			60
Coordinate	RDP	Position Read			72
	WRP	Position Write			87
	RDE	Encoder Read			70
	WRE	Encoder Write			85
	RDO	Offset Read			71
	WRO	Offset Write			86
Information	STR	Status Read			84
	RSY	System Setting Information Read			78
	RMS	Motor Setting Information Read			75
	RMP	MPC Setting Information Read			74
	RES	(ESI) Encoder Setting Information Read			73
	IDN	Version Read			64
Speed Table	WTB	Speed Table Setting Information Write			88
	RTB	Speed Table Setting Information Read			79
Teaching	TAS	Teaching Function Axis Information Set	2 axes		89
	TMS	Teaching Function Position Information Set	2 axes		90
	RDT	Teaching Function Position Data Read	2 axes		92
	WRT	Teaching Function Position Data Write	2 axes		92
	TPS	Teaching Function Teaching Drive Teaching	2 axes		91

(To be continued to next page)

Commands that are usable in SC-021 are as in the table below. For details, refer to the pages for respective commands.

(Continuance of previous page)

Type	Description	Command		Applicable model SC-	Page
		Function		021	
Easy control (Internal setting dependence)	PMS	Easy Control	Speed Change		93
	PMP	Easy Control	Relative Position Drive		94
	PMA	Easy Control	Absolute Position Drive		95
	PMH	Easy Control	Origin Search		96
Measurement	SCN	Continuous Scan			97
	RBU	Scan Data Read			99
	SFT	Fixed Time Measurement			101
Drive aid	RCP	Constant Pulse Read			103
	WCP	Constant Pulse Write			103

MEMO

【Revision History】

Date	Version	Contents of revision
2011.02.14	1.00	First version release



Kohzu Precision Co., Ltd.