

Motor Driver(5-Phase stepping motor driver) SD-5C

M A N U A L



Thank you very much for selecting Kohzu products.

For your safety, please read the following before using.

Caution for your safety

- ※Please keep these instructions and review them before using this unit.
- ※Please observe the cautions that follow:
 - Warning** Serious injury may result if instructions are not followed.
 - Caution** Product may be damaged, or injury may result if instructions are not followed.
- ※The following is an explanation of the symbols used in the operation manual.
 - Caution:** Injury or danger may occur under special conditions.

Warning

- In case of using this unit with machinery(Nuclear power control, medical equipment, vehicle, train, airplane, combustion apparatus, entertainment or safety device etc), it is required to install fail-safe device, or contact us.** It may result serious damage, fire or human injury.
- Installation, connection, operation, control, maintenance should be executed by person who has been qualified.** It may cause a fire or human injury, give an electric shock.
- Please use DC power with reinforced insulating the primary and secondary part for the DC power product.** It may give an electric shock.
- Please install this unit after considering counterplan against power failure.** It may cause human injury or damage to product by releasing holding torque of motor.
- Do not use this unit outdoors or place where there are flammable, corrosive gas, water, combustibles and frequent vibration etc.** It may cause a fire or give an electric shock.
- Do not disassemble and modify this unit, when it is required, please contact us.** It may cause a fire or give an electric shock, damage to product.
- Please install protection equipment on board type product.** It may cause a fire.

Caution

- Power input voltage must be used within the rated specification and power line should be over than AWG NO. 18(0.75mm²).** It may cause a fire or give an electric shock.
- Please check the connection before supplying the power.** It may cause a fire or give an electric shock, damage to product.
- Please turn off power when power is failed.** It may cause human injury or damage to product due to sudden movement by recovering from power failure.
- Do not touch this unit during the operation or after a while of operation.** It may cause a burn due to high temperature in surface.
- The emergency stop should be enabled during the operation.** It may cause human injury or damage to product.
- Please supply power after checking control input signal.** It may cause human injury or damage to product by sudden movement.
- Do not turn on the HOLD OFF signal input while it is maintaining vertical position.** It may cause human injury or damage to product by releasing holding torque of motor.
- Please install a safety device when it is required to maintain the vertical position after turn off the power.** It may cause human injury or damage to product by releasing holding torque of motor.
- Please check if HOLD OFF signal input is ON when setting the output manually.** It may cause human injury by sudden movement.
- Please stop this unit when mechanical trouble is occurred.** It may cause a fire or human injury.
- Do not touch the terminal during the insulation dielectric strength test or insulation resistance measurement.** It may give an electric shock.
- Please observe the rated specification.** It may cause human injury give an electric shock or damage to product.
- In cleaning the unit, do not use water or an oil-based detergent.** It may cause a fire or give an electric shock.
- Please separate as industrial waste when disuse this unit.**
 - ※The above specifications are changeable at anytime without notice.

Features

- Full/Half step
- Bipolar constant current pentagon drive method.
- STOP/RUN current adjustable
- Photocoupler input insulation method to minimize the effects from external noise.
- Power supply : 20-35VDC

Specifications

Model	SD-5C
Power supply	20-35VDC(3A Max.)
RUN current	0.5-1.5A/Phase(Max.)
RUN method	Bipolar constant current pentagon drive
Resolution(Rotating angle)	×1(0.72°), ×2(0.36°)
Pulse width	Min. 0.5μs
Pulse interval	Min. 0.5μs
Rising/Falling time	Max. 1μs
Max. input pulse frequency	50kpps
Pulse input voltage	High:4-8VDC, Low:0-0.5VDC
Input resistance	390Ω(CW, CCW, HOLD OFF)
Ambient temperature	0 ~ 40°C (at non-freezing status)
Ambient humidity	35-85%RH
Unit weight	Approx. 74g

※Please mount the product in ventilative place due to too much heat of driver when using over 30VDC.

Dimensions

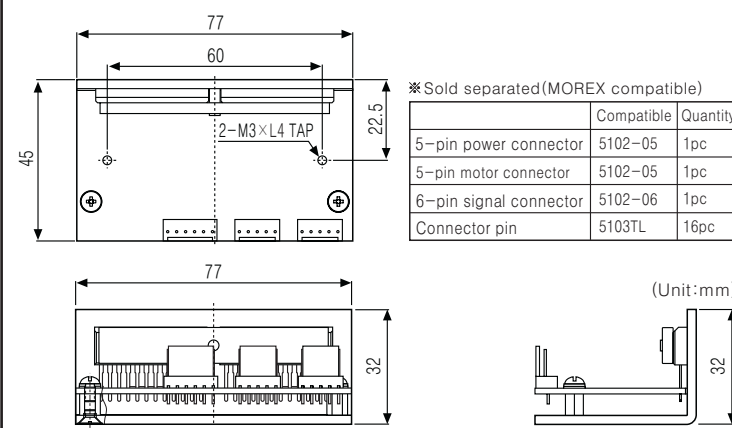

Signal input circuit and time charts

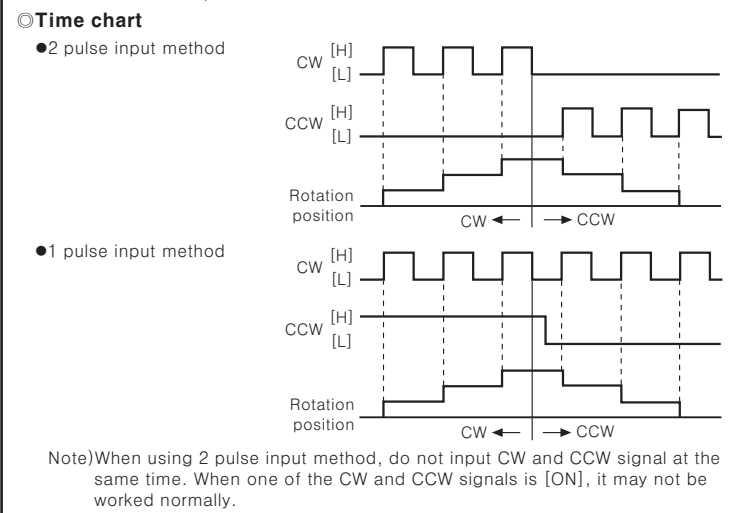
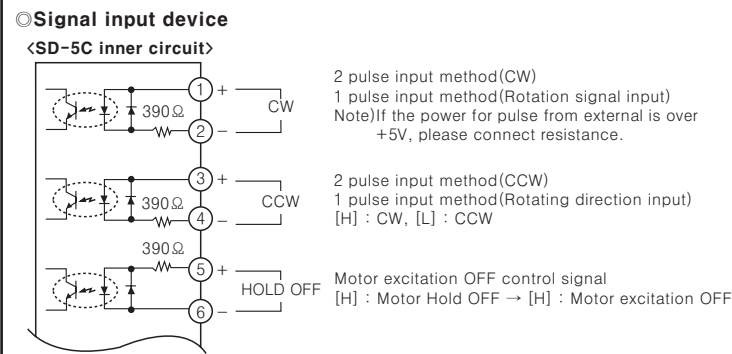

Connections

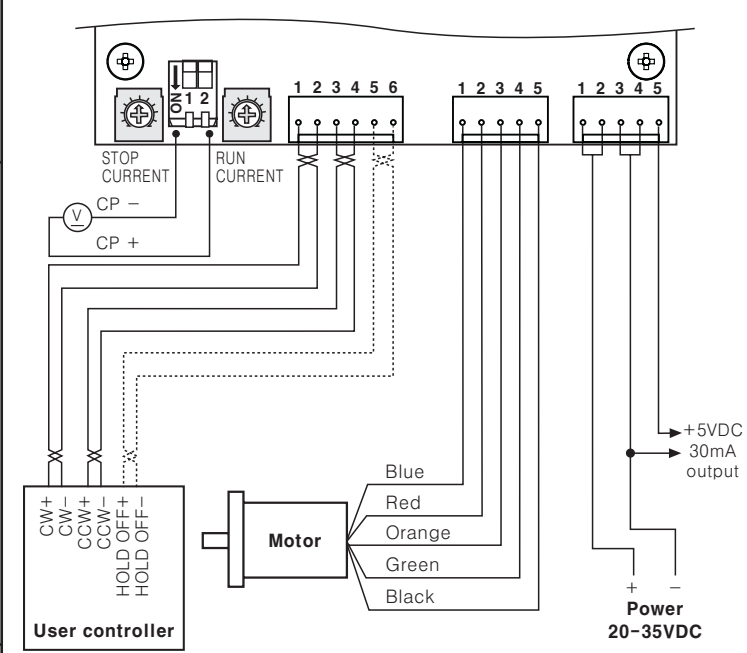

Input · Output circuit and connection diagram

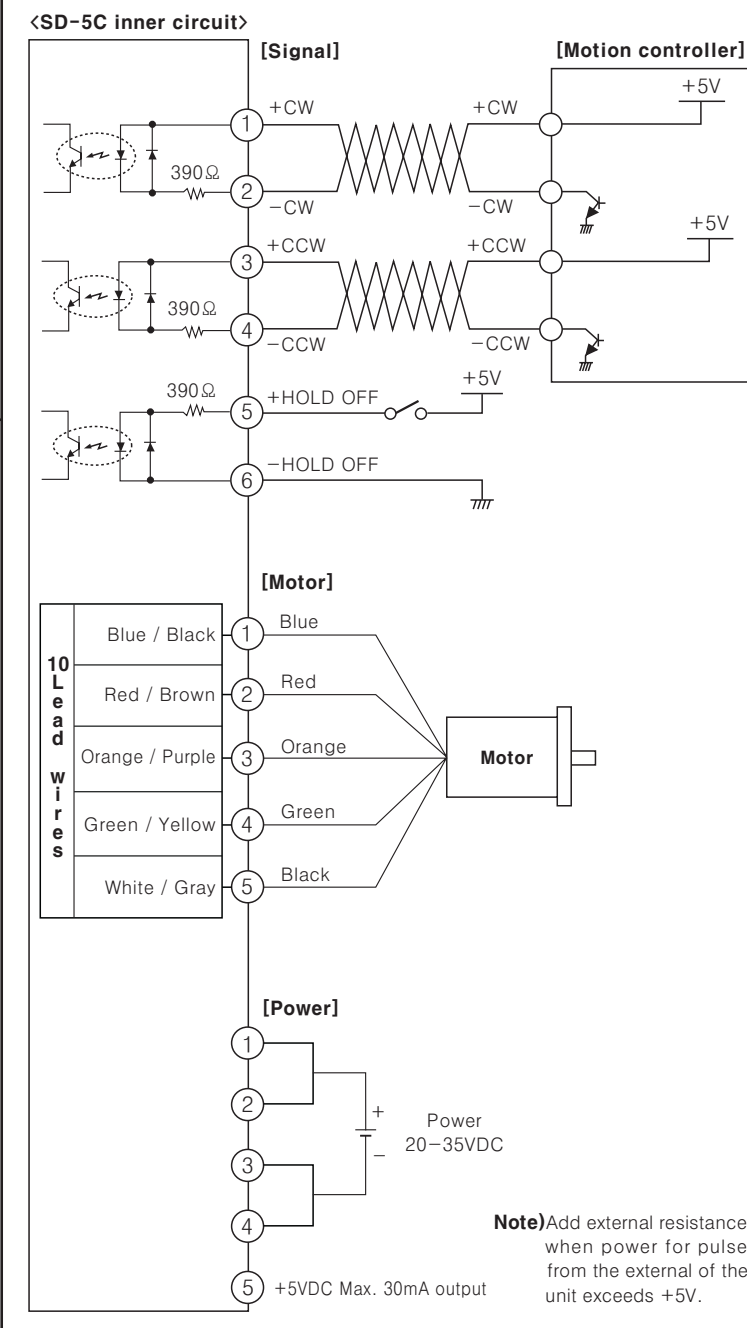

Selectable function switch

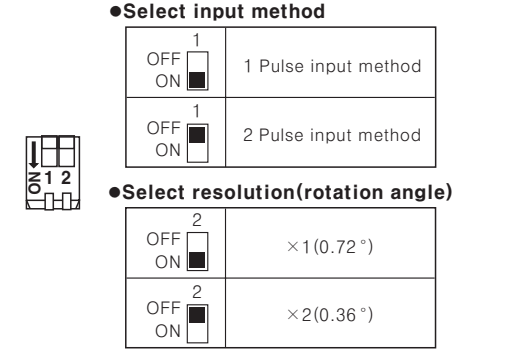

RUN current setting

●Adjust RUN current by an adjuster to prevent temperature rise and suppress the vibration of motor and driver.

●To change the RUN current, connect the CP- to the (-) terminal of the voltmeter and the CP+ to the (+) terminal of the voltmeter then adjust RUN current switch.
(Factory specification of Run current is 1.4A/Phase)

●Phase current change :
Setting current(A) = $\frac{\text{CP measurement voltage(V)}}{2}$

(Note)RUN current should be changed during the operating of motor.

Motor STOP current setting

●Reduce the heating of motor by adjusting the current supplied to motor and at standstill status with STOP current adjuster.

●STOP current is percentage of RUN current.
Ex)After setting 1.0A for RUN current then put STOP current adjuster at 50%, STOP current will be 0.5A.

25% 75% (Note)RUN current should be changed during the operation.

Caution for using

- Signal input
 - When using 2 pulse input method, do not input CW and CCW signal at the same time. When one of the CW and CCW signal it [ON], it may not be worked normally.
 - When the power for pulse operation is exceeded +5V, please connect resistance and use from the external.
- Power supply
 - Use the power enough to supply the run current when turn on the power.
 - The current value indicated on power supply is the max. input of driver.
 - Please check the polarity of power before using.**
- For cable connection
 - Use Twist pair(Over 0.2mm²) for the signal cable should be shorter than 2m.
 - Please use over than AWG No.18(0.75mm²) wire for motor and power connection(when it is required to be extended) and power line.
- For installation
 - Please mount a heating panel on metal surface closely.
 - Please mount this product in ventilative place in order to increase the heating efficiency of heating panel.
- Installation environment
 - It shall be used indoor
 - Altitude max. 2000m
 - Pollution degree 2
 - Installation category II

※It may cause malfunction if above instructions are not followed.



Kohzu Precision Co., Ltd.
2-6-15 Kurigi, Asao-ku, Kawasaki Kanagawa 215-8521, Japan
Telephone: 81-44-981-2131
Facsimile: 81-44-981-2181
Email: e-sale@kohzu.co.jp
Web: http://www.kohzu.co.jp/index.html